

CockburnCentral  
**WEST**  
AT THE TOWN CENTRE



*Artist impression for illustrative purposes only.*

REVISED NOVEMBER 2017

APPROVED DOCUMENT  
ORDINARY COUNCIL MEETING 14 DECEMBER 2017



LANDCORP

# Contents

<b>1. Introduction</b>	<b>3</b>		
1.1 Vision and Objectives	3		
1.2 Community	5		
1.3 Design	5		
1.4 Economic	5		
1.5 Environment	5		
<b>2. Structure and purpose</b>	<b>6</b>		
2.1 Purpose	6		
2.2 Structure	6		
2.3 Discretionary Clause	7		
2.4 Relationship to Other Planning Instruments	7		
2.5 Land Use	7		
<b>3. Approval Process</b>	<b>8</b>		
<b>4. Climate</b>	<b>9</b>		
4.1 Climatic Zone	9		
4.2 Local Conditions	9		
<b>5. Existing Context</b>	<b>10</b>		
5.1 Site Context and Analysis	10		
5.2 Topography and Soil Condition	11		
5.3 Influential Site Features and the Natural Environment	11		
<b>6. Urban Design</b>	<b>13</b>		
6.1 Preface	13		
6.2 Desired Character	13		
6.3 Diversity & Ground Floor Adaptability	15		
6.4 Place Legibility	16		
6.5 Public Domain Interface	16		
6.5.1 Public Spaces	17		
6.5.2 Public Domain Interface Principles	18		
6.6 Development Context	19		
6.7 Public Art	19		
6.9 Access and Parking	20		
6.8 Safety and Surveillance	20		
6.9.1 Access	21		
6.9.2 Vehicle Parking	22		
6.10 Signage (Commercial Development Only)	23		
<b>7. Built Form Design</b>	<b>24</b>		
7.1 Building Envelopes	24		
7.2 Primary Building Controls	24		
7.2.1 Site Planning, Orientation and Setbacks	25		
7.2.2 Building Separation	26		
7.2.2.1 Tower Building Envelopes	27		
7.2.3 Height	28		
7.2.4 Floor Levels	29		
7.3 Architectural Character	29		
7.3.1 Facades	30		
7.4 Materials and Colours	31		
7.5 Building Entrances	31		
7.6 Roof Forms	32		
7.7 Outdoor Space	32		
7.7.1 Communal Outdoor Areas	33		
7.7.2 Private Outdoor Living Areas	33		
7.8 Building Services	34		
7.8.1 Waste Management	34		
7.8.2 Drying Areas	34		
7.8.3 Storage	34		
7.8.4 Mechanical Services	35		
7.8.5 End of Trip Facilities	35		
7.9 Fencing and Balustrades	36		
<b>8. Environmentally Sustainable Development</b>	<b>37</b>		
8.1 Climate Responsive Design	37		
8.1.1 Solar Design	37		
8.1.2 Shading	37		
8.1.3 Ventilation	38		
8.2 Energy Efficiency	38		
8.3 Water Efficiency	39		
8.3.1 Plumbing Fixtures	39		
8.3.2 Stormwater Management	39		
8.4 Lighting	39		
8.5 Acoustics	40		
8.5.1 Landuse Generated Noise	40		
8.5.2 Road Noise	40		
<b>9. Landscape Design</b>	<b>41</b>		
9.1 Deep Root Zones	41		
9.2 Hardscaping	42		
9.3 Softscaping	43		
9.4 Water Efficiency and Maintenance	44		
9.5 Construction Zone	44		
<b>10. Site Specific Building Requirements</b>	<b>46</b>		

# 1. INTRODUCTION

## 1.1 Vision and Objectives

“Cockburn Central West will be an innovative mixed use development integrating regional recreational aspirations into the existing landform and surrounds, whilst extending the urban fabric of the highly successful Cockburn Central Town Centre.”



Artist impression for illustrative purposes only



## Master Plan with Indicative Building Layout

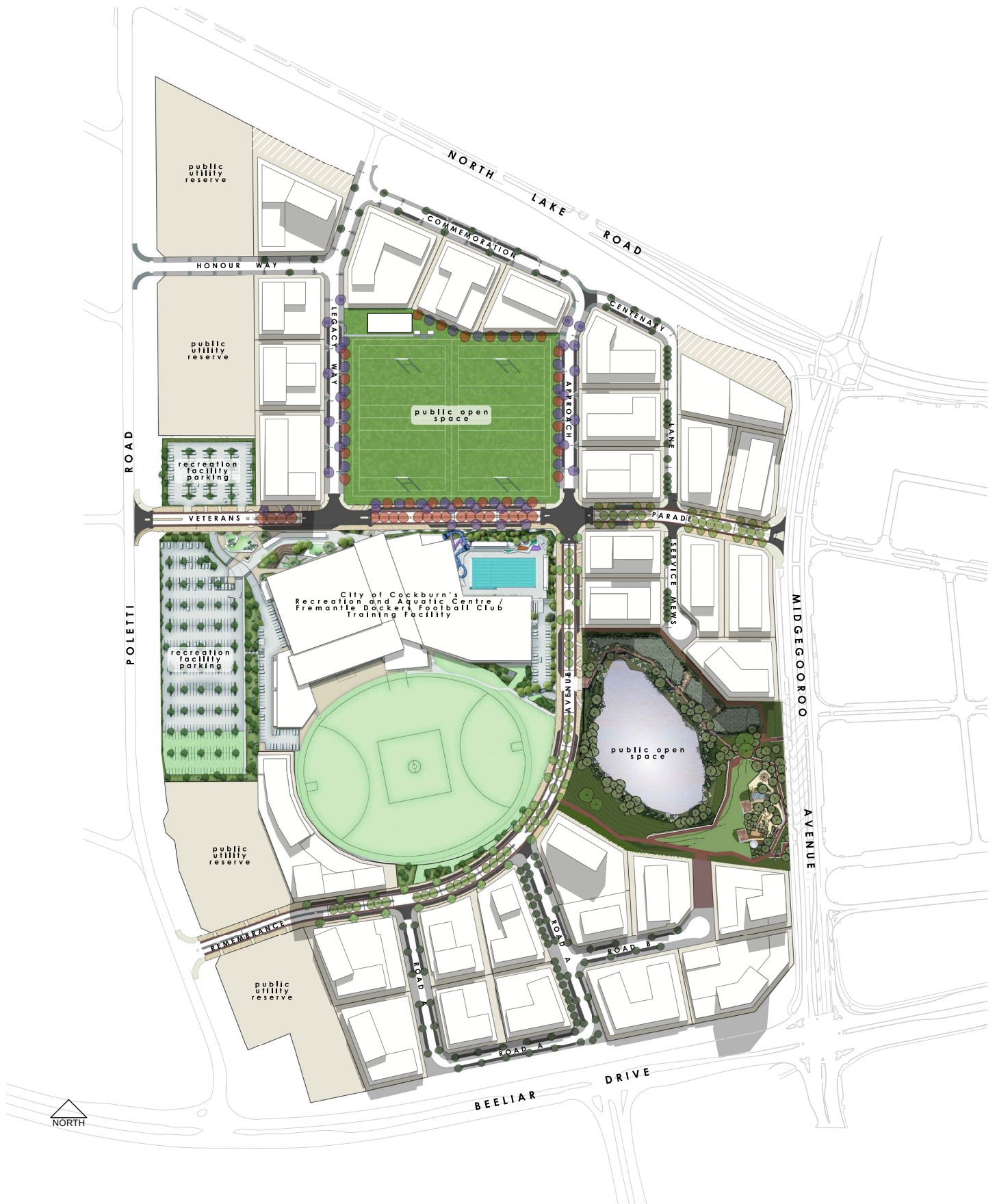



# 1. INTRODUCTION

This project vision is underpinned by the following overarching objectives for the site. These key objectives inform all design objectives and development criteria within these guidelines.

## 1.2 Community

- Achieve a liveable and interactive urban development through specific built form responses to unique recreational elements.
- Enhance community activity through integrated land use opportunities.
- Emphasise the open space elements as key features of the precinct through appropriately oriented developments that assist in framing the three key open spaces.
- Provide strong connections to the surrounding community infrastructure, local amenity and transport alternatives.

## 1.3 Design

- Establish an architectural response that is compatible with the local character of the neighbouring Cockburn Central Town Centre.
- Maximise comfort, appeal and safety of the pedestrian environment through appropriate detailing of ground floor building interfaces.
- Provide a range of typologies that deliver functional, sustainable, lively, integrated and attractive buildings.
- Ensure buildings exhibit design excellence at public/private interfaces.

## 1.4 Economic

- Strengthen the Activity Centres role as the primary location in Cockburn for the location of strategic and knowledge intensive businesses. This is likely to be achieved through the provision of quality public spaces and diverse office space options.
- Optimise economic opportunities by promoting flexible ground floor built form that can accommodate residential and alternative uses such as retail and commercial.
- Achieve high levels of dwelling diversity and affordability initiatives appropriate to the location and future housing needs.

## 1.5 Environment

- Enrich the environmental qualities and character of the locality through appropriate building interfaces.
- Maximise the environmental amenity for all residents through considered position of outdoor spaces for visual links to the wider green network.
- Establish opportunities for green corridors that promote deep soil planting and local micro climate benefits.
- Promote high performance buildings that demonstrate excellence in environmentally sustainable design.

## 2. STRUCTURE AND PURPOSE

### 2.1 Purpose

These Design Guidelines apply to all private land development within the Cockburn Central West precinct. The Design Guidelines will ensure that developments enhance the proposed character of the area whilst encouraging developments that are innovative in addressing climate responsive design. Specifically, the Design Guidelines promote:

- High quality public realm engagement;
- Building design excellence;
- Sustainable development; and
- Resident liveability.

The Design Guidelines have been adopted as a Local Development Plan by the City of Cockburn to guide development within the Cockburn Central West precinct of Cockburn Central.

### 2.2 Structure

The Design Guidelines are structured in three parts to assist proponents in preparing their designs and applications.

#### Part 1

Introduction, process, existing conditions and context.

These outline the overarching vision, design principles, assessment process and contextual elements which will form the basis for development proposals.

#### Part 2

Design Guidelines - General Provisions. These contain key design requirements that are applicable to all development and lots within Cockburn Central West. These are arranged into the following four elements:

1. Urban Design
2. Built Form Design
3. Environmentally Sustainable Development
4. Landscape Design

For each element, objectives, development controls and design guidance are outlined to describe each design issue.

#### Objectives

The Objectives outline the design intent underpinning the mandatory development controls and explain the desired outcome. These objectives need to be met for all development proposals.

#### Development Controls

The Development Controls provide the minimum requirements that shall be met for all development proposals. These controls address most of the objectives, but proposals shall ensure that all of the objectives are addressed.

In order to encourage innovation, applicants are also provided the opportunity to meet or exceed the vision/objectives through alternative solutions, to the satisfaction of the Design Review Panel (DRP).

#### Design Guidance

The Design Guidance section recommends some additional measures by which a proposal can achieve a higher level of sustainable design, community interaction and/or architectural character.

#### Part 3

Design Guidelines - Site Specific Provisions. These articulate the mandatory controls and details particular to individual lots or groups of lots - 'sites'.

## 2. STRUCTURE AND PURPOSE

### 2.3 Discretionary Clause

An important provision within the Design Guidelines is the opportunity for applicants to secure the vision for Cockburn Central West through performance based applications.

Alternative design solutions may be considered at the sole discretion of the DRP where it is sufficiently demonstrated that:

- The proposal will comply with the overall vision, objectives and principles of the Design Guidelines.
- There is sufficient justification and particular circumstances which necessitate a variation to the guidelines development controls.

Compliance with the mandatory development controls criteria does not guarantee endorsement. The DRP may refuse endorsement of a proposal that is not considered to be in keeping with the objectives of the Design Guidelines.

Each development proposal will be assessed on an individual basis, and the endorsement of an alternative solution shall not be construed as creating a precedent for determining other developments.

Variations to the Design Guidelines mandatory development controls criteria will only be granted where such exemptions deliver built form design and sustainability excellence.

### 2.4 Relationship to Other Planning Instruments

These Design Guidelines are adopted as a Local Development Plan under the provisions of the Planning and Development Regulations 2015 (Schedule 2, Part 6).

These Design Guidelines shall be read in conjunction with the Scheme, the Cockburn Central West Local Structure Plan (LSP) and any relevant Local Planning Policy.

Residential density codes have not been allocated and will not apply within the Cockburn Central West Precinct. Accordingly, land use and development will be guided by the Design Guidelines and the provisions of the Residential Design Codes do not apply.

### 2.5 Land Use

Cockburn Central West will provide opportunities for retail, office, commercial and residential activity to achieve a vibrant and active destination.

It is envisaged the predominant development form will be medium and high density residential dwellings, however ground floor non-residential land use is mandated at key locations and encouraged in other supporting locations. The specific locations, objectives and development controls are detailed at section 6.3 of these Design Guidelines.

As with any mixed use development, buildings will develop and mature over time and commercial/retail use will establish as demand requires. In the interim, other uses such as residential will be acceptable in the encouraged locations, on the basis that buildings are adaptable and flexible in design to accommodate change to non-residential land use on the ground floor when demand requires.

#### Land Use Permissibility - Statutory

The design guidelines are to be viewed in the context of the Scheme and Cockburn Central West LSP, which regulate land use permissibility applicable to the subject land.

Land use permissibility shall be in accordance with the Site Specific Building Requirements. Where there is an inconsistency between the land use permissibility outlined within the Design Guidelines and the land use permissibility specified in the Scheme/ Local Structure Plan, the land use permissibility specified in the Scheme/Local Structure Plan shall prevail to the extent of the inconsistency.



### 3. APPROVAL PROCESS

The process for a development application relating to all development is summarised below. Minor modifications or changes of use for existing buildings are not subject to this approval process.

#### Design Review - Pre Development Application

- Prior to lodgement of a Development Application, pre-application design review meetings are required involving the Design Review Panel (DRP). A minimum of 3 pre-application meetings are required.
- Following initial design review and plan development, the final meeting with the DRP should include a final detailed drawing package in accordance with Application Form 1 requirements.
- After the successful completion of the final design review meeting, The DRP will provide a written response either endorsing the development plans for lodgement with the City or seeking additional information or modifications for further consideration by the DRP.
- When the above steps are complete, a Development Application can be made to the City of Cockburn.
- The DRP has the authority to provide endorsement for any variations to the requirements of the Design Guidelines.
- Variations to the requirements of the Design Guidelines will only be granted where such exemptions deliver built form design and sustainability excellence whilst still meeting the Cockburn Central West vision and objectives.

#### Development Application Submission

- The applicant lodges a Development Application (DA) with the City of Cockburn with the accompanying DRP final report including LandCorp endorsement.
- The DA is assessed by the City of Cockburn (or Development Assessment Panel, if applicable) in the usual manner.

The following diagram outlines the approval process required prior to any development commencing.

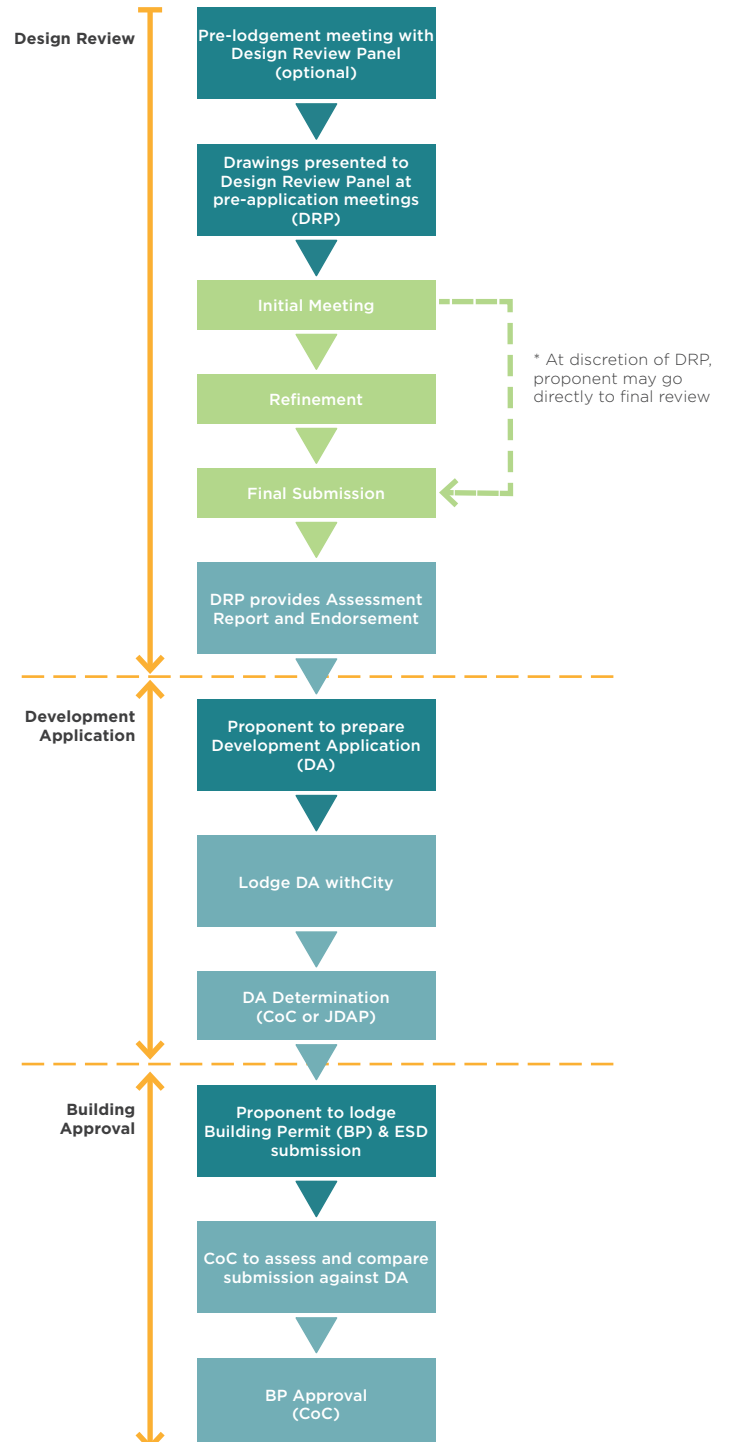

## 4. CLIMATE

### 4.1 Climatic Zone

**ZONE 5: WARM TEMPERATE  
HOT SUMMER - COOL WINTER  
AS/NZS 3500 DG**

Design objectives and controls for development within this climatic zone ensure a high level of environmentally sustainable development (ESD) can be achieved. ESD encompasses environmental, social and economic aspects of a development. ESD objectives and development controls are detailed at section 8.

### 4.2 Local Conditions

Cockburn Central West has a temperate climate, with mild winters and hot dry summers. The summer months from December to February have an average temperature of 30 degrees Celsius during the day and 18 degrees Celsius at night but can rise to and above 44 degrees at the height of summer. The area experiences a very low rate of humidity.

The warm summer days are cooled down in the afternoon with strong sea breezes that blow in from the ocean replacing the hot air trapped above the Perth Metropolitan Area and the Darling Ranges.

The winter months from June to August are mild, with average temperatures of 18 degrees C during the day, and 9 degrees C at night. The wettest month of the year is July, and the average yearly rainfall is around 700mm.

Nights are considered comfortable most of the year, therefore night ventilation and air-purging can be used effectively to help maintain comfortable internal temperatures. From June through to September, night time temperatures may often fall below the comfort limit.

Wind patterns vary from the coast to the inland; in general the winds follow the typical west coast trend of easterlies in the morning and westerlies in the afternoon. In the summer this wind pattern is much more pronounced in particular for coastal areas. Strong afternoon south-westerly breezes typically 20-30 km/h buffet the coastal region and can be used to cool the interiors and assist night purging. In winter the pattern is less predictable mainly because the variations in land temperatures are less extreme, leading to the winter afternoon wind patterns being variable.

## 5. EXISTING CONTEXT

### 5.1 Site Context and Analysis

Cockburn Central West's location within the Core Area of Cockburn's largest activity centre ensures the precinct has an important role to play in the provision of a mix of complimentary land uses including employment, residential development, and community and recreation services.

The precinct is strategically located adjacent to Gateways Shopping City, the Cockburn Train Station and the Cockburn Town Centre.

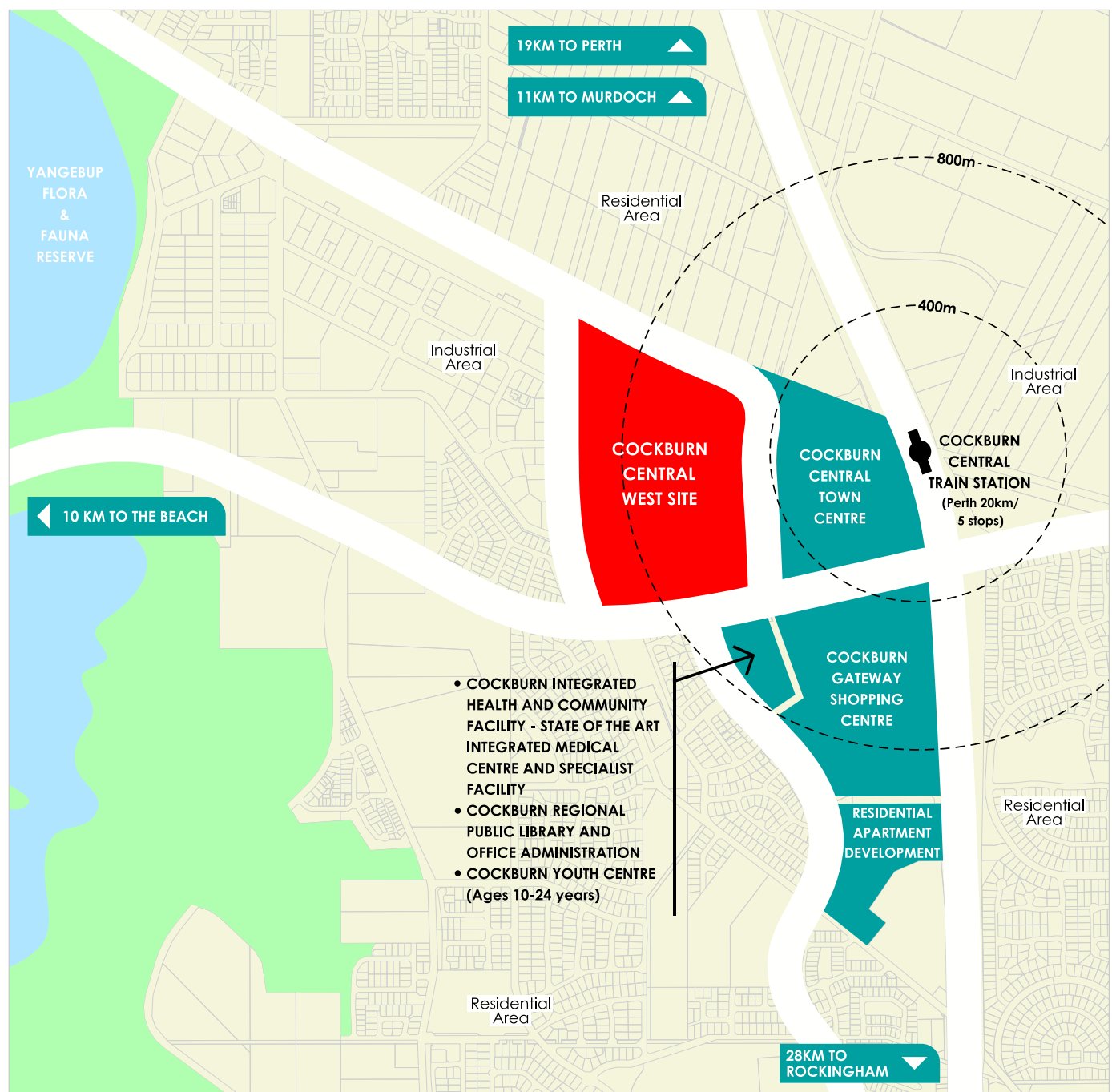

Figure 5.1 Site Context



## 5. EXISTING CONTEXT

### 5.2 Topography and Soil Condition

The site's level changes across its extent and generally falls from 36m AHD in the south-west to 25m AHD in the north-east.

For lots that are adjacent to Midgegooroo Avenue and Beeliar Drive, there are level differences at some interface locations that will require special design consideration.

The ground water table is known to be high in the low lying areas (north-western extent) and will be a key consideration for basement development within buildings in these areas.

The site is generally underlain by a soil profile consisting of Bassendean sands. Such ground conditions are considered to not impose significant geotechnical constraints on potential developments.

### 5.3 Influential Site Features and the Natural Environment

The site contains a wetland that is valuable from an environmental and aesthetic point of view, providing immediate character and amenity to the development.

The western portion of the site comprises existing 330kV overhead powerlines contained within a public utility reserve. In order to maximise the use of this land, provision has been made for short term parking integrated with landscaping within the easement to support the Integrated Facility.

An existing high pressure gas main is located along North Lake Road, which requires appropriate building responses as detailed in the Site Specific Building Requirements (section 10).

The adjacent Cockburn Central Town Centre building development along Midgegooroo Avenue establishes a context for built form massing and height along this important interface with Cockburn Central West.

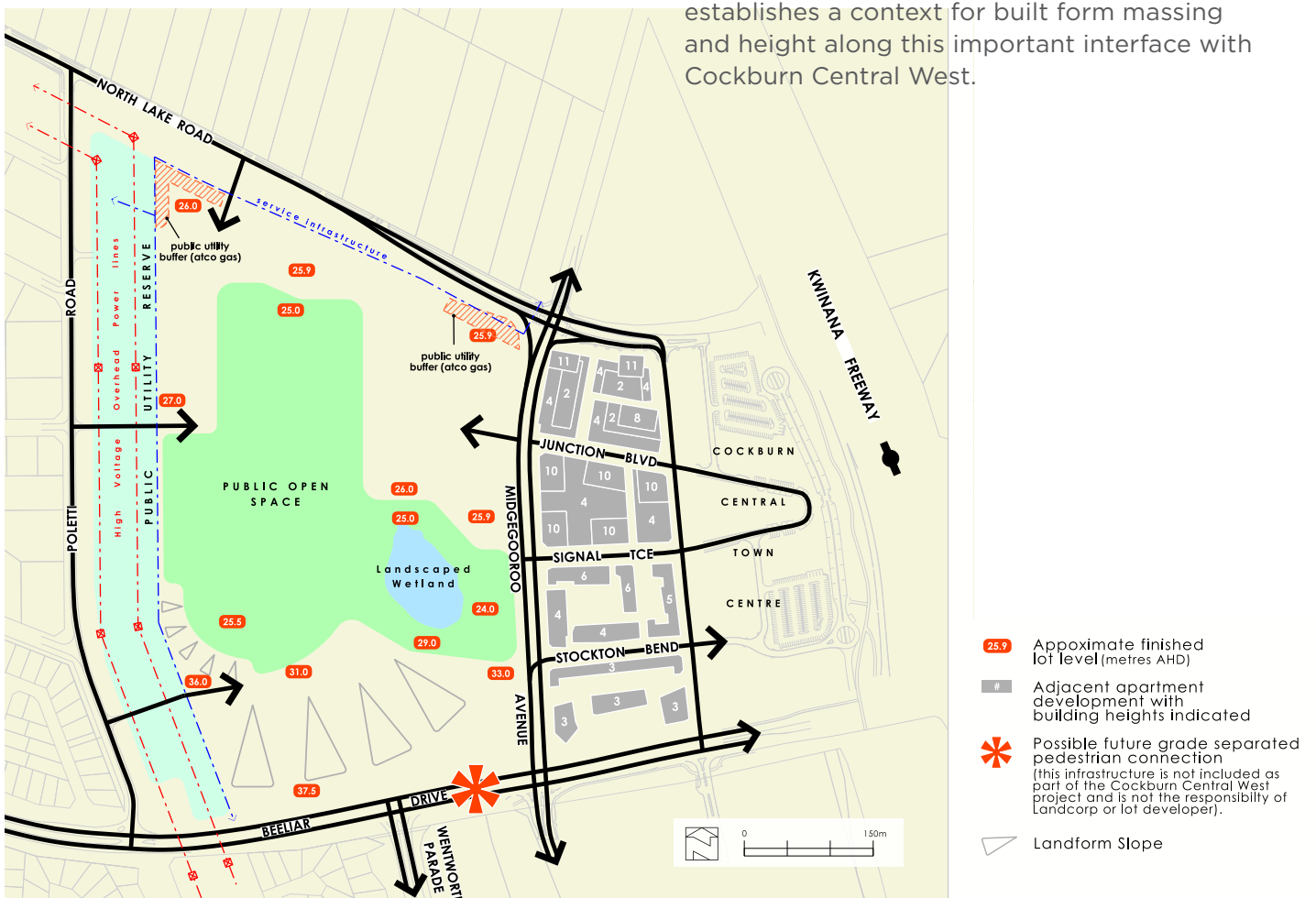

Figure 5.3 Site Considerations

# Part 2

# General Provisions

## 6. URBAN DESIGN

### 6.1 Preface

Cockburn Central West's defining features of passive and active recreation, community and sport facilities offer exceptional amenity and activity for development to respond and contribute to.

Excellent connectivity is provided by way of the proposed road and footpath network in and around the precinct - of particular importance is the connection east towards the Town Centre and south towards Gateways Shopping Centre and the community facilities south of Beeliar Drive.

### 6.2 Desired Character

To achieve the vision for Cockburn Central West requires a strong commitment to design excellence in the built form.

Buildings will be visually interesting from well considered use of materials and textures, colour and the articulation of building form and mass.

High quality buildings with architectural and landscape features will reinforce the character of the public domain and contribute to the creation of public spaces that are enduring, beautiful and comfortable.

The development will deliver a cohesive extension of the Town Centre with well designed, appropriately scaled and articulated buildings.





## 6. URBAN DESIGN

### Urban Design Rationale Diagrams:



**Figure a Public Domain Network**

Public open spaces and key streetscapes define a priority network of public spaces that require appropriate building design response correlated to the adjacent public realm.

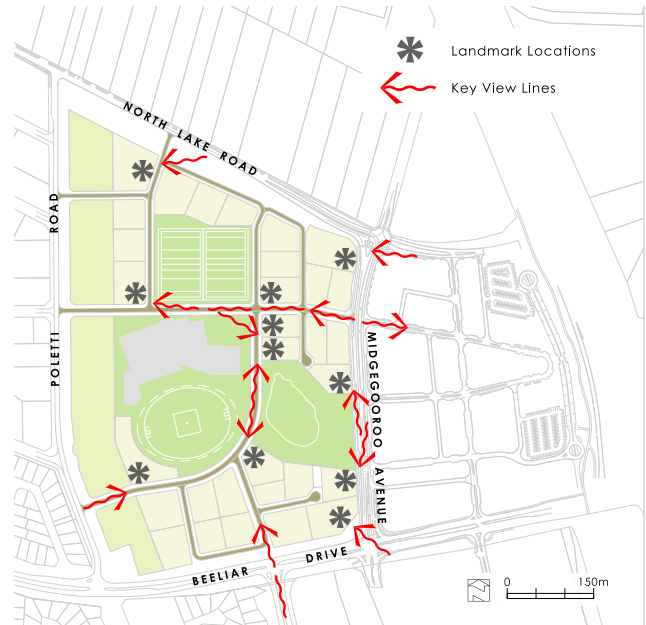

**Figure b Key View Lines and Landmark Sites**

Landmark building locations respond to priority viewlines and public vistas. They maximise legibility around visual linkages by creating a quality pedestrian scale experience.



**Figure c Key Bicycle Connections**

Recreation focus of the Integrated Facility supported through robust cycle connections to this destination location. Building access, lighting and interaction with the street should enhance cycle functionality.



**Figure d Key Pedestrian Connections**

The permeable network connects key Cockburn Central features with safe, direct and interesting pedestrian experiences. These key alignments enhance retail landuse diversity opportunities.

## 6. URBAN DESIGN

### 6.3 Diversity & Ground Floor Adaptability

#### Objectives:

Provide a variety of dwelling sizes, types and price points to cater for a wide range of household types and income levels to achieve equitable housing access and support the future needs of the community.

Supply flexible apartment configurations to support diverse households and adaptability for future stages of life, including single person households, families, multi-generational families and group households.

Family friendly apartment living is encouraged to achieve a diverse residential population and a range of built form outcomes.

Achieve longevity and flexibility in the performance of buildings by ensuring ground floor uses can adapt and transition over time.

To promote lots fronting key pedestrian routes and prominent corner sites as appropriate places for ground level activation via retail and commercial opportunities. For example active ground floor frontages (such as cafes, restaurants, offices and small scale shops) are desired along Veteran Avenue given the route is an important connector between the train station and the Integrated Recreational Facility.

#### Development Controls:

- Adaptable buildings shall have a minimum ground floor to first floor ceiling height of 4.1m in their residential form. This is intended to achieve a 3.5m clearance height when converted to non-residential uses.
- For adaptable buildings, floating floors may be included for interim residential use where ground level separation is desirable to the public realm. This can be removed when floor space is adapted to non-residential tenancies.
- To achieve diversity in unit size and affordability, residential development shall provide a minimum of 20% one bedroom dwellings and 40% two bedroom dwellings in any one development. A balance of three bedroom units is also strongly encouraged to ensure a diverse range of apartment sizes across the Activity Centre Core Area. Development applications shall be supported with a short written statement advising how the proposed development is contributing to the objective of diverse dwelling sizes. Information regarding current dwelling yields, including mix within the Activity Centre Core Area is available from the City upon request.

- Non-residential ground floor development shall be provided where mandated on the Site Specific Building Requirements (section 10).
- Residential ground floor dwellings shall be adaptable to commercial/retail where nominated as 'non-residential land use encouraged' within the Site Specific Building Requirements (section 10).
- Where residential use is to occur at the ground floor in areas nominated as 'non-residential land use encouraged', street elevations shall be designed in the first place as commercial/retail type frontages rather than domestic in scale and design aesthetic.

#### Design Guidance:

- Dual key apartment design is one method of achieving a range of apartment types and sizes, including family households, whilst maintaining a flexible apartment configuration.

#### Performance based bonus criteria:

- Where a development provides an integrated component of non-residential development or adaptable building design at the ground floor level within a building, a nil building setback to the street/lot boundary is permitted.

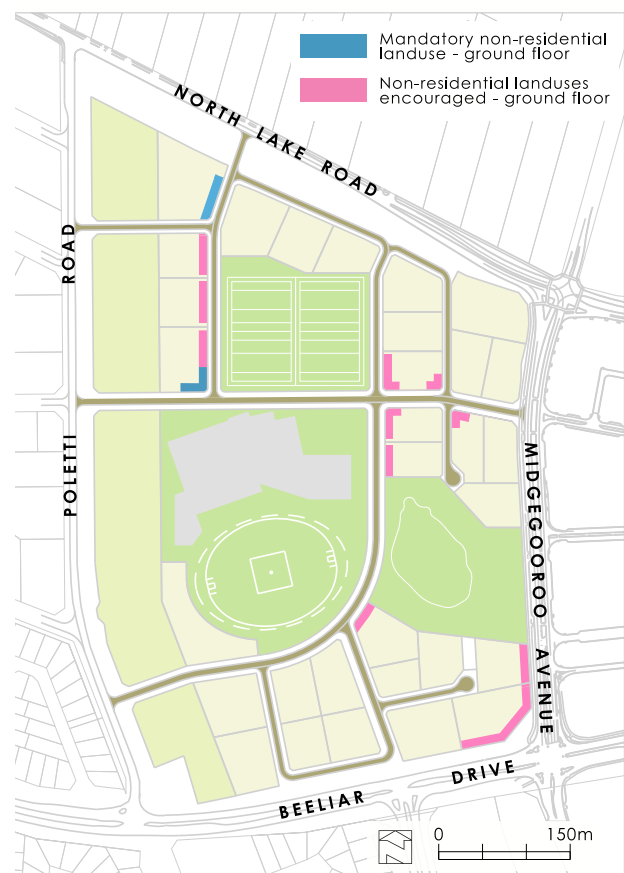

Figure 6.3 Key non-residential locations

## 6. URBAN DESIGN

### 6.4 Place Legibility

#### Objectives:

Maximise legibility and visual linkages with engaging lines of sight between activity points, the open space and recreation facility and Cockburn Central Town Centre.

Enhance amenity and views along key linkages by providing buildings of landmark quality as view terminators and wayfinders.

Address and activate street corners and to create landmarks that assist in defining local character, helping people to navigate easily through the space.

#### Development Controls:

- a. Development shall respond to key vistas and public open space through the positioning, orientation and massing of buildings, landmark and landscape elements.
- b. New developments shall integrate with existing Cockburn Central Town Centre development linkages and viewlines.
- c. Buildings on corners must address both frontages to the street and/or public space and include strong architectural expression.
- d. For Landmark Building locations, design excellence is required in the form of articulation of the building design, proportion, quality, scale, massing and detailing.



Indicative building model illustrating opportunities for landmark building responses

### 6.5 Public Domain Interface

#### Objectives:

To contribute to the activation and vitality of the public realm.

Establish interesting, attractive, safe streets and public spaces for residents, workers, commuters and visitors.

Buildings shall enhance the hierarchical system of landscaped streets and public spaces that give expression and character to the public domain.

Ensure building design and retail areas facilitate the creation of street level activity and visual connections between internal areas of buildings and the external public realm.

Maximise views across public spaces from residences.

Ensure that development interfaces appropriately with the variety of landscape conditions for public open space adjacent private development sites, refer Figure 6.5.1.

#### Development Controls:

- a. Pedestrian access to public open space from adjacent lots shall be provided and integrated into site planning (excluding lots 118, 119 and 120 adjacent to playing fields).
- b. Developments on corner lots shall address both the primary and secondary streets and/or public realm and include strong architectural expression.
- c. Where Pedestrian Access Ways are located, buildings shall achieve appropriate surveillance of these spaces.
- d. Blank walls, vehicle access and building services (e.g. bin store, booster hydrant) shall not exceed 20% of the total lot frontage to the public realm, except for developments on corners where no blank walls will be permitted.
- e. Ensure a fine grain design for the ground plane to promote a sense of layering, texture and visual interest to enhance depth and character of building facades.



## 6. URBAN DESIGN

### 6.5.1 Public Spaces

#### 1 - Integrated Recreation and Community Facility

Combined aquatic and recreation facility, plaza and building forecourt with public seating, pedestrian paths and parking access. This facility is a pivotal space that surrounding buildings will need to respond to in their design and surveillance.

#### 2 - The Oval

A grassed open space to be used for football training and public use as active and passive open space. Adjoining buildings will provide appropriate frontage, orientation and passive surveillance to this space and may include direct pedestrian access.

#### 3 - Playing Fields

Active recreational space for playing and watching team sports and otherwise will be available for passive public use. Adjoining buildings will provide appropriate frontage, orientation and passive surveillance to this space and shall consider overshadowing effect.

#### 4 - Clubrooms

Planned future clubrooms and seating will ultimately be integrated into this space. Adjoining buildings shall consider appropriate interface to this space.

#### 5 - Wetland Park

A unique natural asset with passive recreation and high visual amenity benefits for residents via appropriate building orientation.

#### 6 - Boardwalk Promenade

A formalised pedestrian link around the Wetland Park with an associated hardstand shared path to provide access to adjacent building developments. Adjoining buildings will provide appropriate frontage, orientation and passive surveillance to this space and may include direct pedestrian access.

#### 7 - Naturescaped Playground

A natural themed playground experience adjacent the wetland setting providing active recreational experiences for neighbourhood children.

#### 8 - Wetland Link

A sloping pedestrian link that provides public access between proposed development and the public wetland open space. No vehicle use permitted. Adjoining buildings will provide appropriate frontage and passive surveillance to this space and shall accord with gradients. Direct pedestrian access from buildings is suitable.

#### 9 - Centenary Mews and Service Mews

Pedestrian focussed shared spaces with flush kerbs and trafficable paving. Dense tree planting, parking embayment's and pedestrian areas will enhance amenity of these Mews encouraging pedestrian movement to Wetland Park. Adjoining buildings will provide passive surveillance and pedestrian activation to these spaces.

#### 10 - Wentworth Parade Link

This road link contains an intimate arborway providing a pivotal pedestrian link between Cockburn Central West and Wentworth Parade development. Adjoining buildings will provide appropriate frontage, orientation and passive surveillance to this space. Vehicle driveway locations and quantity shall minimise disruption to this pedestrian link.

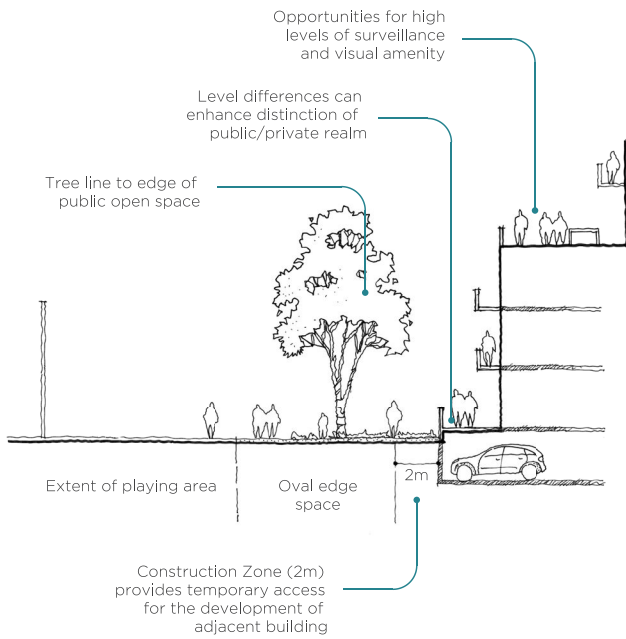
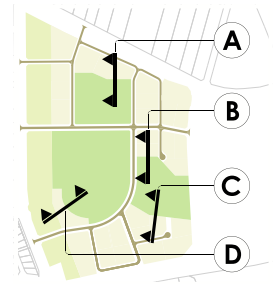

Figure 6.5.1 Location key to public spaces within Cockburn Central West.

## 6. URBAN DESIGN

### 6.5.2 Public Domain Interface Principles

The sections illustrated here are indicative only and demonstrate the proposed public domain outcomes in four key locations and the objectives to achieve appropriate development interfaces.



Section A - Playing Fields

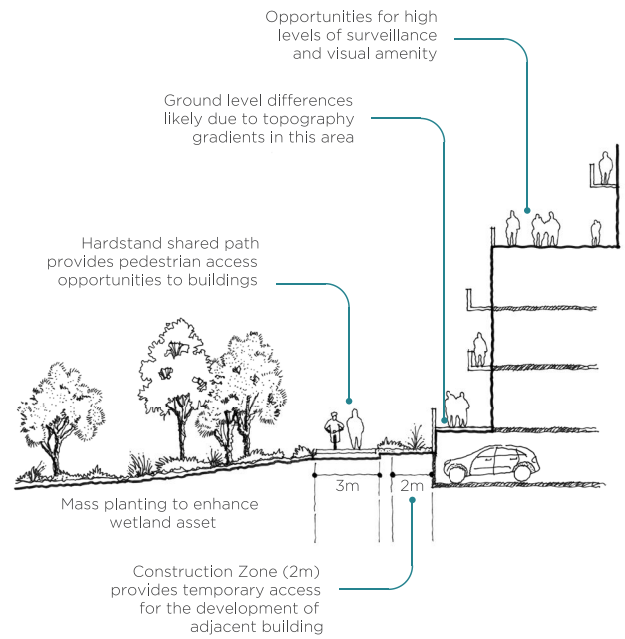

Section C - Wetland Park

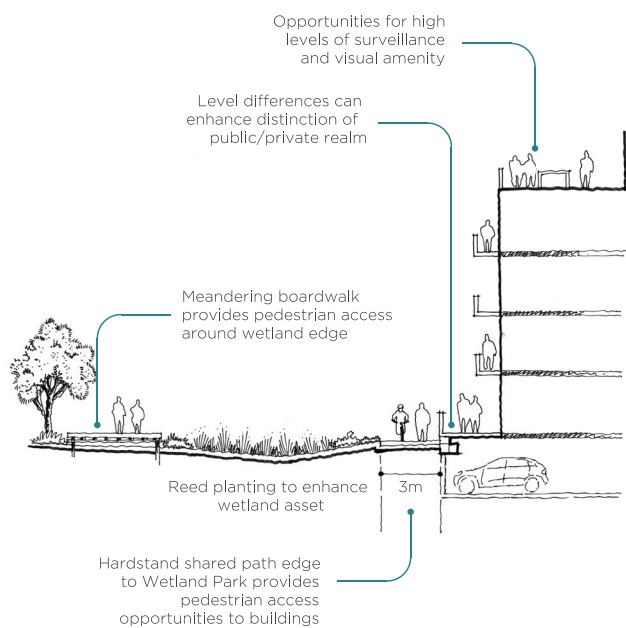

Section B - Boardwalk Promenade

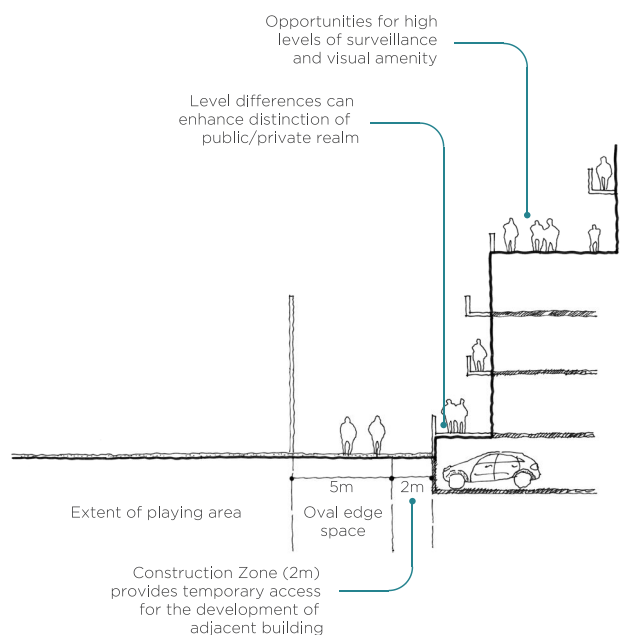

Section D - The Oval

## 6. URBAN DESIGN

### 6.6 Development Context

#### Objectives:

Development should improve, acknowledge and be responsive to surrounding development. This should include private viewlines through to the public domain and appropriate consideration of adjacent site viewlines where applicable.

Create a considered and thoughtful approach to individual development which clearly acknowledges its context, fully contributing to an integrated development precinct.

#### Development Controls:

- a. Design of individual sites must be responsive to neighbouring sites, the existing context and the public realm and provide a positive contribution to the project area as a whole.

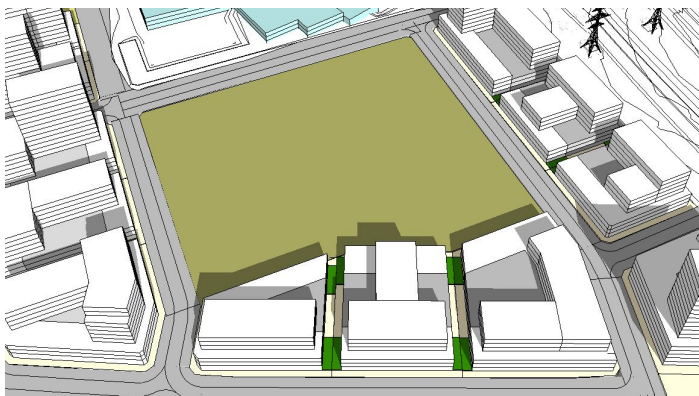

Indicative building model illustrating development viewlines and building breaks



Building edges interacting with adjacent public realm

### 6.7 Public Art

#### Objectives:

Foster a strong sense of character and identity within Cockburn Central West.

Ensure public art is an early consideration of the development proposal and displays excellence in design, whether integrated into the building or stand alone installations.

Enhance and expand the quality of the built environment and public facilities and improve the amenity and accessibility of public spaces.

#### Development Controls:

- a. Public art elements shall involve a professional artist and shall be submitted for the approval of the DRP with application for Design Guideline endorsement.
- b. All development proposals shall accord with City of Cockburn Local Planning Policy LPP5.13 requirements and eligibility details.

#### Design Guidance:

- a. Public art should be integrated into construction projects from their inception and not as an 'add on' after the building has been designed or constructed.



Public art can be integral to the building and interactive



## 6. URBAN DESIGN

### 6.8 Safety and Surveillance

#### Objectives:

Encourage opportunities for casual surveillance from buildings into the public realm that are sympathetic to the desired character for the area.

Maintain a clear but integrated distinction between the public and private realm.

#### Development Controls:

- a. The size and position of windows from habitable rooms, balcony openings, hospitality and commercial areas shall be designed to promote natural surveillance of the public realm.
- b. Developments are to incorporate design principles of Crime Prevention Through Environmental Design (CPTED).
- c. Developments should be designed to engage with and activate the public realm, particularly at ground level.
- d. Proposed pedestrian access ways shall provide adequate lighting and natural surveillance to meet the CPTED guidelines for safety.
- e. Proposed pedestrian access ways shall provide adequate lighting and natural surveillance to meet the CPTED guidelines for safety.

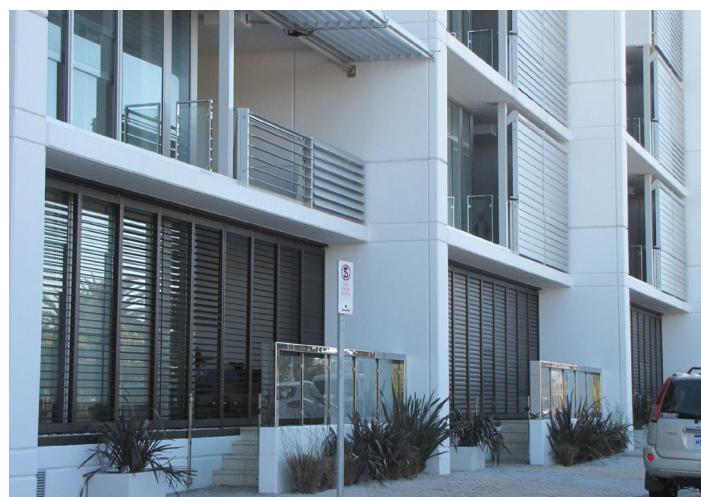

Well positioned balconies and windows to maximise surveillance

### 6.9 Access and Parking

#### Objectives:

Enable convenient, efficient and safe vehicle access and egress within a functional and attractive landscape.

Ensure crossovers and parking areas do not visually dominate a site.

Promote a fair balance between pedestrian, cyclists and vehicle movement.

Ensure that on-site vehicle parking and access are appropriately located to minimise adverse visual impact on the streetscape.

Provide sufficient car parking for the development.

Ensure visitor parking is accessible at all times and located outside any security barrier.

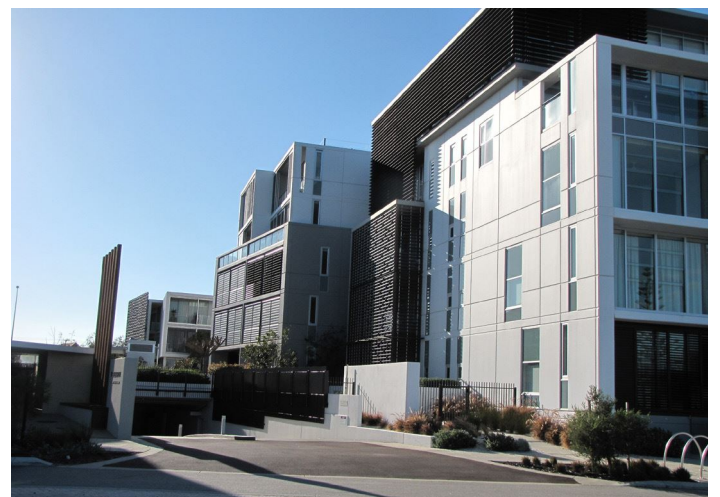

Discrete vehicle entries designed to minimise view from the street



## 6. URBAN DESIGN

### 6.9.1 Access

#### Development Controls:

- a. Crossovers shall not interfere with existing or proposed street trees, or the levels of pavement.
- b. Crossovers should be constructed from a material consistent with the design treatment of the streetscapes and generally respond to the materiality of the verge hard-scaping, either as constructed or proposed. Asphalt crossovers are not permitted.
- c. Paving to vehicle access ways shall be of an equivalent quality to paving used within public realm, while meeting the requirements of heavy vehicles.
- d. Footpaths shall be maintained as the priority movement, with crossovers and car park entries terminating at the footpath. Where vehicle crossovers are agreed with the DRP and cross a key pedestrian route, appropriate measures to promote pedestrian safety shall be included to minimise conflict between pedestrians and vehicle traffic.
- e. Car park entries shall be positioned to minimise visual impact from the public realm and located away from main pedestrian entries. Vehicular access is preferable from a laneway, where possible. Refer Site Specific Building Requirements (section 10).
- f. Car park entries and crossovers shall comply with the Australian Standards.
- g. Car park entries, service areas and bin refuse collection points shall be integrated into the development of each lot and screened from view.
- h. For all proposed commercial or retail tenancies, a Servicing Management Strategy is to be prepared in conjunction with City of Cockburn.

#### Design Guidance:

- a. Wherever possible, buildings should be constructed up to and above a vehicle accessway.
- b. Street trees shall not be removed or damaged. If street trees are required to be removed for construction purposes, written permission is first required from the City. If permission is granted then the same size tree is to be provided as a replacement.



Undercroft parking to the rear of a site not visible from the street.

## 6. URBAN DESIGN

### 6.9.2 Vehicle Parking

#### Development Controls:

- a. Any above grade parking adjacent to priority streets and public realm areas shall be sleeved with habitable/active uses (residential, retail or commercial).
- b. Basement or concealed decked parking shall not be visible from the street or public realm and shall be screened by innovative wall detailing, patterning and vegetation to diversify the building design.
- c. Basement level parking development is limited to a maximum height of 1.2m above ground level where the property interfaces with the public realm.
- d. Parking bay(s) shall comply with the Australian Standards.
- e. The maximum width of car parking and basement access shall be 6.5m and shall not be co-located.
- f. Ground floor parking shall not be proposed within the front setback area.
- g. Lighting design for parking outcomes shall consider light spill and amenity for apartments (on-site and adjacent developments).
- h. Any open air parking outcomes shall minimise adverse visual impacts for overlooking residents, which should include screening such as shade structures.

#### VEHICLE PARKING RATIOS

Car parking shall be provided in accordance with the Cockburn Central West LSP and the City of Cockburn Town Planning Scheme, where applicable (refer to Table 8 below for the Structure Plan provisions). The following vehicle parking rates are to be used as a guide and where justified may be varied by Council in accordance with the Scheme.

- Bicycle parking ratio: for retail/office and mixed use - 1 space per 100 m<sup>2</sup> NLA.
- Residential bicycle parking space - 0.5 spaces/10 dwellings (secure undercover).
- Residential visitor bicycle parking spaces - 1 space/10 dwellings.
- Motorcycle parking ratio: 5% of total number of car parking bays (additional).
- Adaptable dwellings (where residential dwellings have been designed for conversion to commercial tenancies or vice versa): Car parking ratio as per residential parking standards. No further bays will

#### VEHICLE PARKING IN COCKBURN CENTRAL WEST

Use Class	Minimum and Maximum Number of Car Parking Bays
Residential Dwelling Minimum (Studio, 1 or 2 bedroom)	Studio/1 Bedroom – 0.75 bays 2+ Bedroom - 1 bay/dwelling
Residential Dwelling Maximum (Studio, 1 or 2 bedroom)	Not to exceed double the minimums
Residential Dwelling Minimum (3 + bedrooms)	1 bay/dwelling
Residential Dwelling Maximum (3 + bedrooms)	2 bays/dwelling
Residential Visitor Car Parking	1 bay/4 dwellings up to 12 dwellings 1 bay/8 dwellings for 13 <sup>th</sup> dwelling and above
Retail (where the built form does not facilitate an easy transition to 'Office' use)	4 bays per 100m <sup>2</sup> GFA
Office (where the built form does not facilitate an easy transition to 'Retail' use)	2.5 bays per 100m <sup>2</sup> GFA
Mixed Use (where the built form facilitates alternative opportunities to 'Office' and 'Retail' uses)	3 bays per 100m <sup>2</sup> GFA

## 6. URBAN DESIGN

### 6.10 Signage (Commercial Development Only)

#### Objectives:

To ensure signage is high quality, well designed and integrated with the building fabric.

Balance the commercial and way finding needs of tenants and visitors whilst maintaining visual quality and legibility of the public realm.

#### Development Controls:

- a. Signage shall be located on a maximum of one wall for each commercial tenancy within a building, except where a tenancy or building has more than one street frontage.
- b. Pole or pylon signs and illuminated roof signs are prohibited.
- c. All signage must meet criteria noted in current Local Planning Scheme and relevant local planning policy by laws (including the City of Cockburn's Signage Local Planning Policy) and have an approved signage design as part of the Development Application prior to placement of any signage or advertising on commercial development.



Example of street signage integrated with building design

## 7. BUILT FORM DESIGN

### 7.1 Building Envelopes

A building envelope describes the outer limits for any construction on a site. It is not an indication of the final building form, mass or scale, merely it provides a set of limits to be defined in relationship to certain characteristics of a site (topography) or to control fundamental environmental access (solar access, views).

Building envelopes have been carefully crafted for most of the development sites at Cockburn Central West. The objective is to enhance the public open space and streetscape, protect solar access and views whilst ensuring optimal outcomes for all residents and users.

Based upon these building envelopes a series of controls have been established to describe and provide quantitative criteria to proponents in order to assist them in meeting the Development Controls. The building envelopes are presented at the Site Specific Building Requirements (section 10).

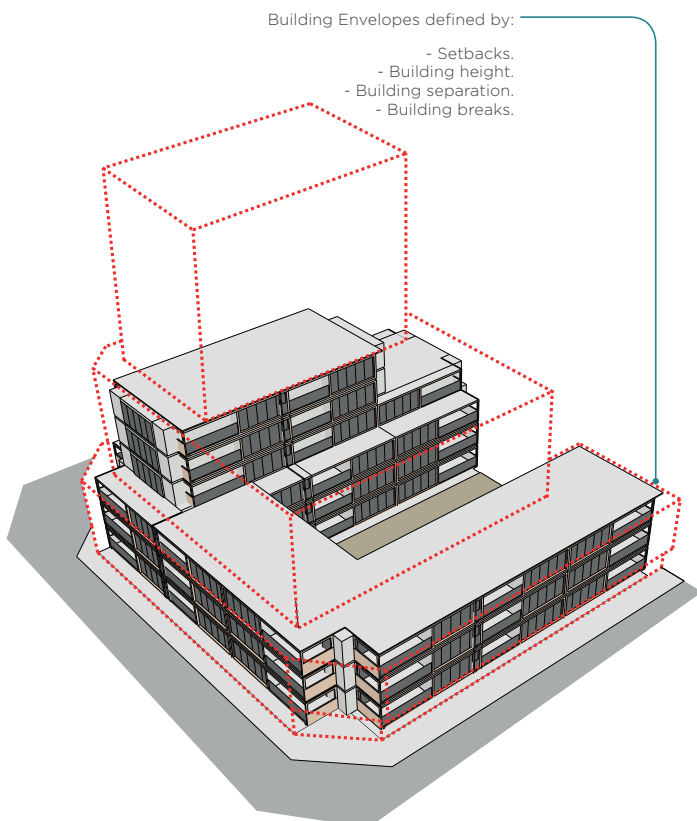

Figure 7.1 Indicative Building Detail shown only

### 7.2 Primary Building Controls

#### Objectives:

To ensure future development responds to the desired bulk, scale and character of Cockburn Central West.

To allow for each building to have adequate access to daylight and natural ventilation as well as visual and acoustic privacy.

To create streetscapes and public open space edges with a building scale in keeping with the desired character for each area.

Building types and layouts are oriented to respond to the streetscape and individual site promoting amenity and urban form character within the development and for neighbouring properties.

Innovative and aspiring building design is encouraged to explore alternative methods to satisfy the podium and tower street setback objectives.

To allow each building the opportunity to have a visual connection with public open space areas from the communal open space area(s).



## 7. BUILT FORM DESIGN

### 7.2.1 Site Planning, Orientation and Setbacks

#### Objectives

Building orientation must consider the site, the street and neighbouring buildings to maximise residential amenity, including urban form to the street, solar access and visual privacy.

#### Development Controls:

- a. All street setbacks where not specified in the site specific building requirements shall meet an average of 3m, with a minimum setback of 1.5m, measured from the lot boundary.
- b. Development above podium height (3-5 storeys) shall set back a minimum of 3 metres from the street building edge, except locations where an alternative setback is set in the Site Specific Building Requirements (section 10).
- c. A minimum open space of 20% of the lot shall be required (excluding balconies and driveways).
- d. Development shall comply with Figure 7.2.1 for street, laneway, rear and public open space setbacks.
- e. Minimum side and rear setback distances for podium elements of the buildings shall be:
  - 6m between walls with major openings/balconies
  - 4.5m between walls with major openings/balconies and walls with no major openings
  - 3m between walls with no major openings
  - 0m for party walls, parking structures or walls with no openings
- f. Balconies shall be located entirely within the lot boundary.

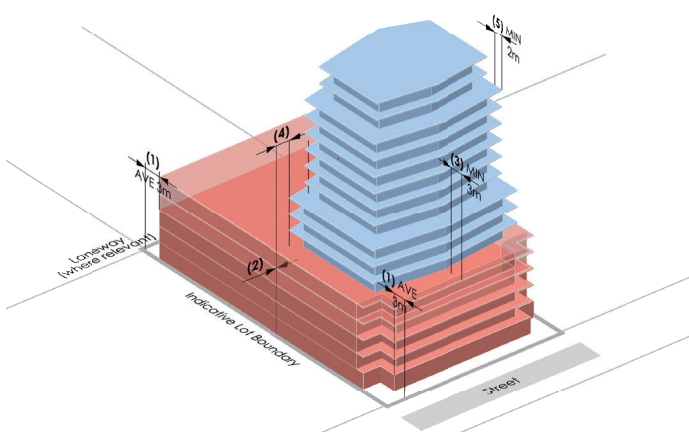

\* Top two levels of all buildings in excess of 8 storeys.

Ref	Building Setbacks	
(1)	Podium (to street/laneway lot boundary)	3m average; no maximum
(2)	Podium (to side/rear lot boundary)	Minimum 0m; No maximum, subject to building configuration
(3)	Tower (to street podium building edge)	Minimum 3m; no maximum
(4)	Tower (to side/rear building edge)	Refer Tower Setbacks Detail (7.2.1.1)
(5)	Building Top* (to tower edge)	Minimum 2m; no maximum

Figure 7.2.1 - Building Setbacks Illustration and Table

## 7. BUILT FORM DESIGN

### 7.2.1.1 Tower Setbacks

**Development Controls:**

- a. Minimum side and rear boundary setback distances for buildings above the podium shall be determined by conditions detailed at Figure 7.2.1.1.

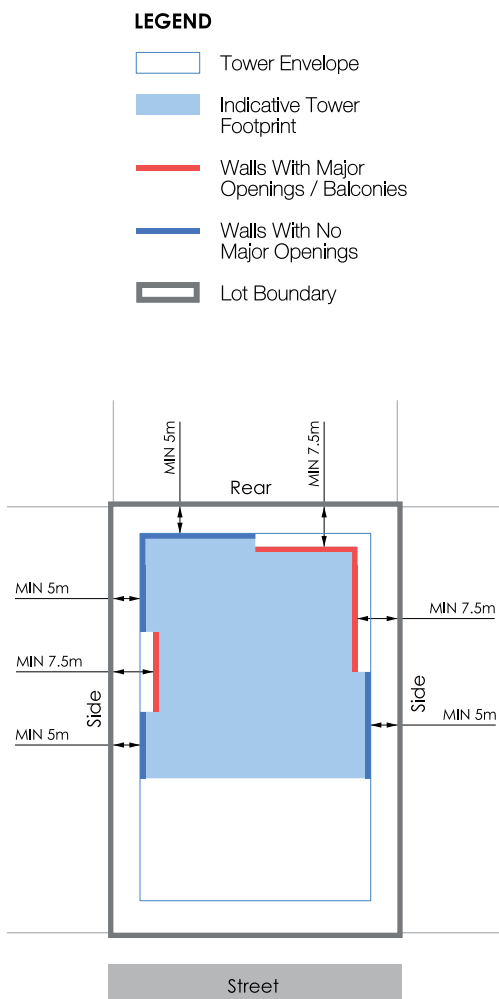

Figure 7.2.1.1: Tower setbacks to side and rear boundaries illustration

### 7.2.2 Building Separation

**Objectives:**

Ensure that new development is scaled to support the desired future character with appropriate massing and spaces between buildings.

Assist in providing residential amenity including visual and acoustic privacy, natural ventilation, sunlight and daylight access and outlook.

Provide suitable areas for communal open spaces, deep soil zones and landscaping.

**Development Controls:**

- a. Minimum separation distances between podium elements of the buildings shall be:
  - 12m between walls with major openings/balconies
  - 9m between walls with major openings/balconies and walls with no major openings
  - 6m between walls with no major openings
- b. Minimum tower separation distances are detailed at Figure 7.2.2 and are to be set back from each other as though there were a boundary between them.
- c. Facade building breaks are required in key locations as noted on the Site Specific Building Requirements (section 10).
- d. Building separation is measured from the outer face of building envelopes (including balconies).

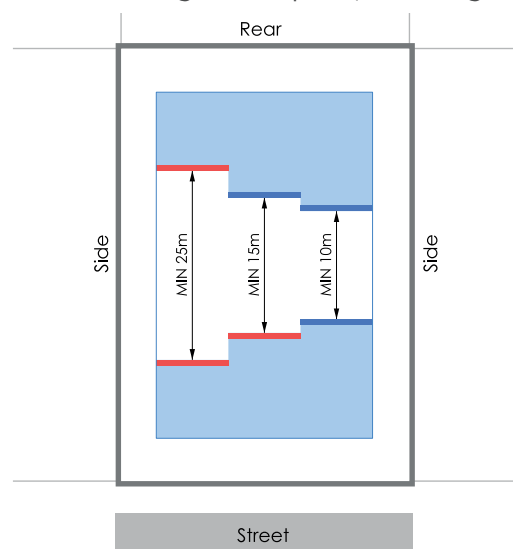

Figure 7.2.2: Building separation illustration

# 7. BUILT FORM DESIGN

## 7.2.2.1 Tower Building Envelopes

**Objectives:**

To ensure an appropriate scale of development relative to the streetscape, public and private spaces.

Ensure that proposed buildings bulk and height achieve the desired urban form where there is no plot ratio requirement and building height of an estimated 17 storeys is achievable.



**Development Controls:**

- a. Tower building envelopes are determined by applicable setbacks to site boundary and/or podium building edge (refer 7.2.1).
- b. For developments of 8 storeys or below, there is the flexibility to incorporate more than one tower. The maximum combined tower floorplate is equivalent to 60% of the tower envelope.
- c. For all building heights of 9 storeys and above: development sites shall be restricted to 1 tower element only per 2500m<sup>2</sup> of lot site area.  
E.g. If 3 lots were amalgamated by landowners, and the total land area was less than 1.0ha, then there is the potential that 3 towers may be achievable.

- d. For developments of 9 storeys and above, the tower element is restricted to the maximum dimensions of 900m<sup>2</sup> maximum (approximately 45m x 20m).
- e. For developments that abut the northern boundary of POS, the shorter side of the tower dimension shall orient to the POS.

Note: A storey is defined as a complete horizontal section of a building (continuous or practically continuous). Dimensions outlined at section 7.2.4.

**LEGEND**

-  Tower Envelope
-  Indicative Tower Footprint
-  Lot Boundary

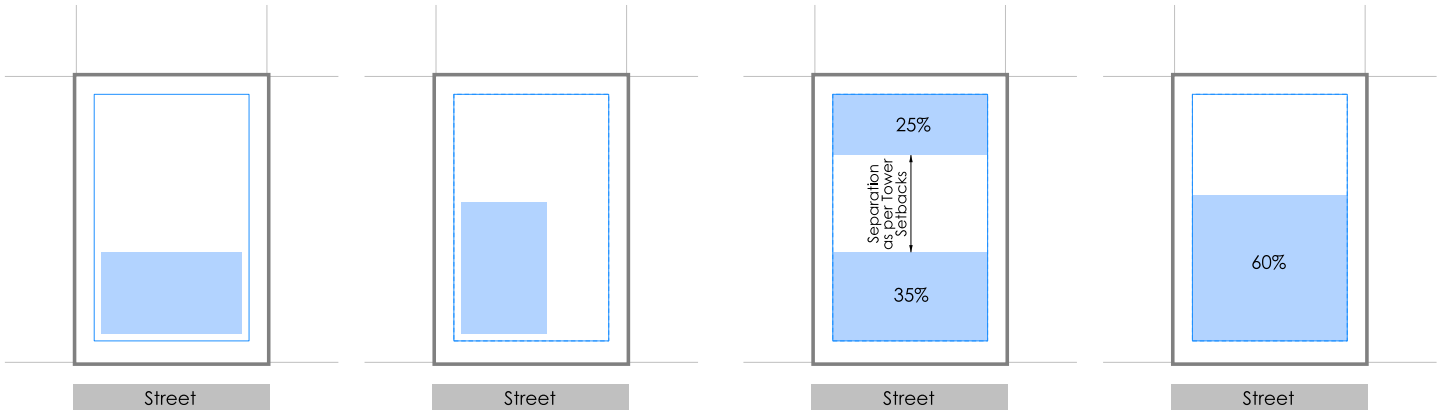

Tower coverage examples within building envelope for 9 storeys and above

Tower coverage examples within building envelope for 8 storeys and below

Figure 7.2.2.1 Building Tower Illustrations

## 7. BUILT FORM DESIGN

### 7.2.3 Height

#### Objectives

To optimise density without compromise to urban and architectural quality.

To ensure building heights are within the limitations set by the Jandakot Airport flight path contours.

#### Development Controls:

- All development shall be a minimum of three storeys along street frontages except where noted on Site Specific Building Requirements.
- Building Height may be reduced to two storeys to allow for attached grouped dwellings, providing the extent of grouped dwellings does not exceed 30% of the developable land area within any parcel of land.
- All multiple dwelling development shall include a podium with a height minimum of 3 storeys and a maximum of 5 storeys.
- Maximum building height will be guided by limitations imposed by the Jandakot Airport flight path contours and where noted on Site Specific Building Requirements (section 10).
- Refer to the below website for additional information:

[www.jandakotairport.com.au/images/files/ControlledActivity/Jandakot-OLS.pdf](http://www.jandakotairport.com.au/images/files/ControlledActivity/Jandakot-OLS.pdf)

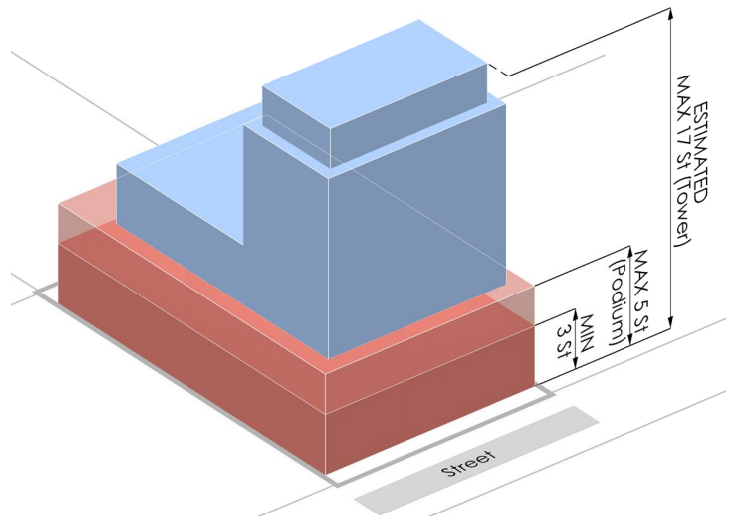
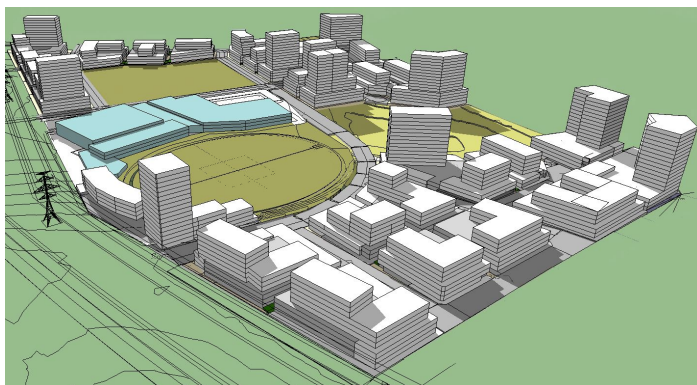

Figure 7.2.3 Building Heights Illustration



Indicative building model illustrating desirable articulation in height.

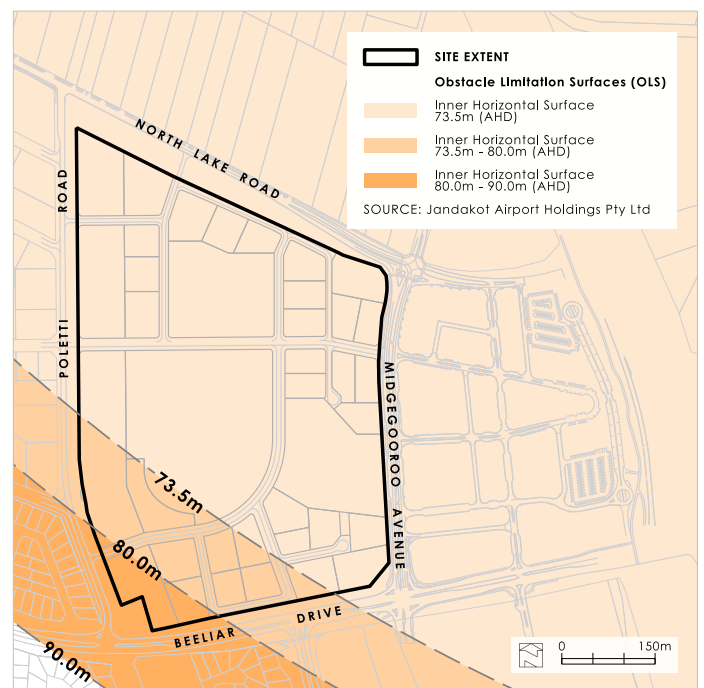

Figure 7.2.3.1 Obstacle Limitation Surfaces (OLS)



## 7. BUILT FORM DESIGN

### 7.2.4 Floor Levels

#### Objectives:

Where level changes occur on sites, ensure floor levels and entrances to buildings appropriately interface with the ground plane.

Ensure that all buildings create an inclusive and accessible environment for all people and achieve their intended function.

#### Development Controls:

- a. Floor to floor heights on the ground floor retail and commercial tenancies shall be a minimum of 3.5m, except for food and beverage tenancies which shall be minimum of 4.0m. This may only be varied to meet site specific level constraints at discretion of DRP.
- b. For commercial tenancies, changes in internal floor levels shall be a maximum of 1.2m (parallel with the street). Where larger internal level changes are needed, they shall occur at least 5m back from the building edge.
- c. To provide direct access to ground floor active use premises (at point of access), finished floor levels are to correspond to the adjacent footpath for universal access.
- d. Residential developments shall have minimum floor to ceiling height of 2.7m to habitable rooms.
- e. Residential ground floors shall not be more than 0.9m above natural ground level at any point.



There is the potential for alternative methods to satisfy street character and front setbacks.

### 7.3 Architectural Character

#### Objectives:

To provide a contemporary architectural response with active edges at ground level and articulated facades above.

To encourage innovative and imaginative developments that promote a cohesive urban form and reinforce the public streets and spaces, in particular the recreational elements.

To provide variety, articulation and high quality built form outcomes that enhance the visual amenity of the development.

#### Development Controls:

- a. Long street facades shall contain building breaks at a maximum of every 40m.
- b. Continuous horizontal and vertical elements shall be broken into smaller components through architectural features, materials, textures and building breaks.
- c. Street level awnings with a minimum width of 2.0m must be provided to ground floor commercial/retail developments.
- d. Street level awning structures shall be a minimum 2.7m and maximum 3.5m above the footpath.



Example of shading devices promoting building character through articulation and material variety.

## 7. BUILT FORM DESIGN

### 7.3.1 Facades

#### Objectives:

Provide buildings with appropriate composition and response to their location.

Ensure the facade responds to the buildings use, pedestrian realm activity and environmental conditions.

#### Development Controls:

- The character and composition of the building elevations shall respond to the specified edge conditions within the precinct (Figure 7.3.1).
- Four distinct elevation types shall be reflected as indicated in Figure 7.3.2.
- The appropriate facade treatments shall:

- Achieve enclosure and privacy from westerly sun, powerlines, and road noise and create a formal urban edge.
- - -** Achieve a sense of privacy and protection from road noise without dominating the adjacent public realm and development.
- - -** Take advantage of the internal views of the open space, create a sense of ownership and achieve surveillance.
- .....** Additional screening may be required for protection from westerly sun and wind patterns. Facades should maintain their internal views of the open space to create a sense of ownership and achieve surveillance.



Figure 7.3.1: Edge Conditions



Figure 7.3.2: Facade Treatments

## 7. BUILT FORM DESIGN

### 7.4 Materials and Colours

#### Objectives:

Convey a contemporary and high quality urban aesthetic.

#### Development Controls:

- a. Developments shall incorporate a variety of materials such as rendered masonry, face brick, stone, steel, glazing and cladding materials, to achieve a contemporary urban aesthetic.
- b. Consideration of thermal and general environmental performance shall be demonstrated in the selection of materials and colours.
- c. Each application for planning approval is to be accompanied with details on proposed materials and colours, together with sample swatches.



Variety of building design elements and materials add visual interest

### 7.5 Building Entrances

#### Objectives:

To provide entrances that read intuitively as the public interface of a building and describe the particular use or activity to which the entrance leads.

#### Development Controls:

- a. Pedestrian entrances shall be clearly defined and separate from vehicle access.
- b. Commercial and residential entries shall be separate and well defined.
- c. Entries for the ground floor level and upper level areas shall be designed separate.
- d. Building entrances shall be designed and located to be highly visible, sheltered, well lit spaces that optimise the safety and convenience of residents and visitors.
- e. Building entrances shall be designed to assist with interest and fine grain at the ground level.
- f. Where long ramps are required to any public street frontage, they should be provided wholly or partially within the building rather than externally to reduce their visual impact and assist in achieving a strong built edge to the street boundary.



Example of a clearly defined pedestrian entry



## 7. BUILT FORM DESIGN

### 7.6 Roof Forms

**Objectives:**

To integrate the design of the roof into the overall façade, building composition and desired development context.

To consider relationships between adjacent buildings and across the Town Centre precinct.

To ensure the roof area does not negatively impact on the views from adjacent dwellings.

**Development Controls:**

- a. Design consideration shall be given to the view of the roof, roof plant equipment and cantilevered elements (e.g. awnings) from adjacent streets, taller buildings and the greater public realm (including ovals and parklands).
- b. Illuminated signage is not permitted as part of the roof design.
- c. Details of air conditioning and roof plant equipment to be discussed at design review stage.



Examples of contemporary roof forms

### 7.7 Outdoor Space

**Objectives:**

To contribute to the sense of safety and liveliness of the street and adjacent public open space.

To achieve a unique building character and resident experience by ensuring developments have strong visual connections with the three key public spaces.

To provide residents with high amenity passive and active outdoor recreational opportunities within their development.

To provide an appropriate balance between the requirement for privacy and views towards the public realm and considering the privacy of adjacent dwellings.

To ensure that balconies, terraces, roof gardens and other outdoor spaces are an integrated component of the development and contribute to the form, articulation and identity of buildings.

To ensure private open space is commensurate in size and composition to the dwelling.

To ensure the design of communal outdoor areas considers building bulk and privacy to adjoining private open spaces and habitable room windows (in compliance with the overlooking requirements of these Design Guidelines).

To ensure communal outdoor areas provide for a range of spaces for different groups of people to gather within.

To consider the provision of communal outdoor spaces for workers within non-residential buildings.



## 7. BUILT FORM DESIGN

### 7.7.1 Communal Open Space

#### Development Controls:

- a. Passive solar access to usable outdoor areas shall be optimised.
- b. Where lots directly abut public open space, communal open space location shall be prioritised to be accessible from, or provide a direct visual connection to these areas.
- c. Minimum open space requirement:
  - Up to 10 dwellings - no requirement
  - 11 to 20 dwellings - 10% site area
  - 21 to 30 dwellings - 15% site area
  - 31+ dwellings - 20% site area
- d. Where communal open space cannot be provided on the ground level, it should be provided on a podium or roof.

### 7.7.2 Private Outdoor Living Areas

#### Objectives:

All residential units to have access to functional and usable private open space that is suitable for the purposes of relaxation and entertaining and is commensurate in size and composition to the dwelling.

Where unique development constraints or

competing development controls inhibit delivery of balconies, alternative performance based solutions may be considered by the DRP.

#### Development Controls:

- a. All apartments shall be provided with at least one balcony or equivalent accessed directly from a habitable room with a minimum area of 10m<sup>2</sup> and a minimum dimension of 2.5m. Studio apartments 40m<sup>2</sup> and smaller may have a Juliette balcony (full height opening windows with a balustrade).
- b. Balconies, terraces, or courtyards are to be provided for all dwellings fronting the public realm.
- c. Balcony balustrades shall be visually permeable to 50% of the area.
- d. All ground level dwellings shall have an outdoor living area relative to the size of dwelling, directly accessible from an internal living space:
  - <80sqm dwelling = 12sqm min. outdoor space
  - 80-120sqm dwelling = 16sqm min. outdoor space
  - >120sqm dwelling = 20sqm min. outdoor space
- e. Overlooking between balconies and adjoining residences shall be carefully considered and privacy screening provided where necessary.
- f. A balcony that is fully enclosed by operable louvers, sliding panels or bi-fold doors and has a hard floor surface continuous with the internal area can be included as private open space.



Example of communal open space benefits to development amenity

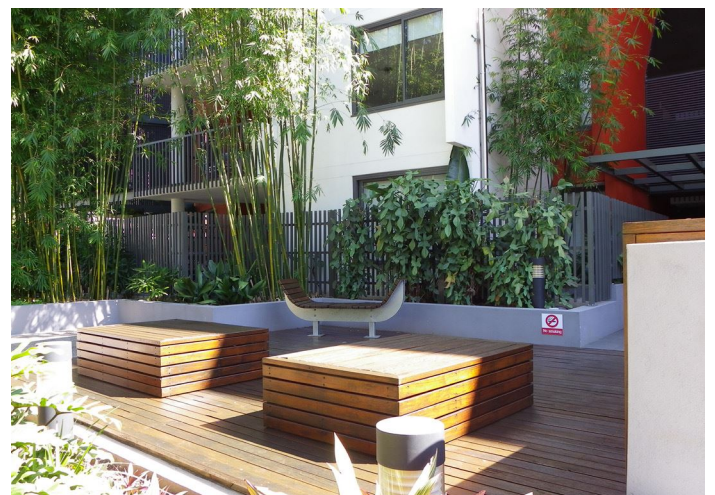

Example of ground level courtyard opportunities

## 7. BUILT FORM DESIGN

### 7.8 Building Services

#### Objectives:

To ensure services are well integrated and have minimal visual impact from the public realm.

To provide efficient and effective building servicing while minimising visual and acoustic impact.

#### 7.8.1 Waste Management

##### Development Controls:

- An integrated Waste Management Strategy shall be prepared in consultation with the City of Cockburn.
- Waste storage facilities shall be designed to allow collection of waste from within the site or a strategy for transfer of waste developed within the waste management strategy.
- Waste collection areas shall be located and designed so they are not visible from the public realm and screened from view.
- Waste collection areas shall be located behind the primary building line, incorporated into the building with a quality material, compatible with the building design.

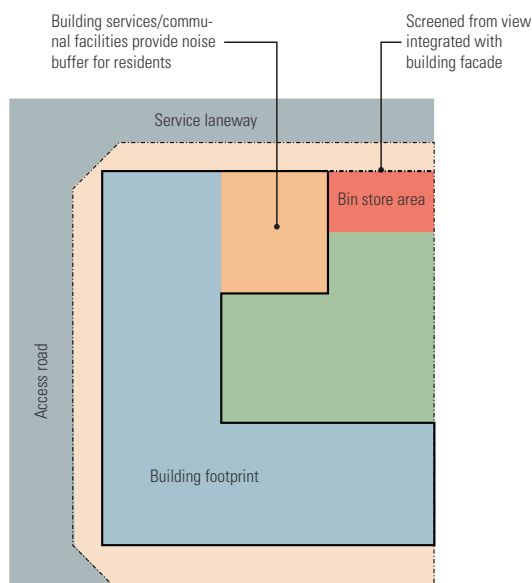

Figure 7.8.1 Integrated Design Illustration

- Bin storage areas shall be located to minimise the impact on adjoining residences and screened from public view.

#### 7.8.2 Drying Areas

##### Development Controls:

- A naturally ventilated drying cupboard/ area shall be provided to each dwelling. This may be within a secondary balcony if provided.
- Any drying area shall be screened from view but well ventilated.

#### 7.8.3 Storage

##### Objectives:

To ensure apartments are provided with adequate and well designed storage.

##### Development Controls:

- Adequate storage for non-residential functions shall be incorporated into the building design.
- Storage not located in apartments shall be conveniently located, accessible and nominated for individual apartments.
- Storage areas shall be a minimum of 4m<sup>2</sup> per dwelling.
- A minimum of 50% of the required storage may be located within the apartment.
- Storage areas at the rear of parking bays must not impede parking access and should contain a roller or sliding door.

## 7. BUILT FORM DESIGN

### 7.8.4 Mechanical Services

#### Development Controls:

- a. Piped and wired services including conduit shall be concealed from view or integrated into the building design.
- b. Building services, including air conditioning units, satellite dishes and other plant equipment shall be screened from view or not be visible from the public realm and minimise acoustic or other impacts.
- c. Building services, including air conditioning units and condensers, shall not be located on balconies or viewed from the public or private realm, unless screened from view in such a way as to be integrated into the building form.
- d. Meter boxes and letter boxes shall be contained within development lots, screened and integrated into the overall development.
- e. Car park venting/service lids and other utility infrastructure or equipments shall not be visible from the adjacent public or private realm and shall be appropriately screened to ensure they do not detract from the visual quality of the development.
- f. Plant, service equipment and lift overruns shall not be visible from the public realm and must not be visible above the roof line of building with street facing elevations.



Example of screened building services for protection of amenity for communal open space

### 7.8.5 End of Trip Facilities

#### Development Controls:

- a. For commercial and retail development with floorspace greater than 500m<sup>2</sup> NLA but less than 2000m<sup>2</sup>NLA, there shall be an allocation of one unisex shower or 1 male/1 female shower.
- b. For commercial and retail development with NLA floorspace greater than 2000m<sup>2</sup> NLA, there shall be an additional allocation of one unisex shower or 1 male/1 female shower per 2000m<sup>2</sup> thereafter.
- c. For all commercial and retail development, there shall be an allocation of one locker per bicycle storage space.
- d. All end of trip facilities shall be designed with convenience and safety in mind.



Example of end of trip facilities.



## 7. BUILT FORM DESIGN

### 7.9 Fencing and Balustrades

#### Objectives:

To ensure design and materials/finish complements and is consistent with the building design.

To ensure fencing and balustrades contribute positively to the quality of the area and enable surveillance of footpaths or other public areas.

Promote fencing of a minimum height suitable to its intended function (e.g. security; safety; screening).

To ensure balustrades and fencing are appropriately selected in response to the design of the internal front setback. Both surveillance to the street and some level of privacy for the space will need to be demonstrated.

#### Development Controls:

- Front fences, balustrades and gates addressing streets shall be at least 60% visually permeable by area, no more than 1.2 m high and uniform in design.
- All fencing, balustrades and gates addressing POS shall be at least 60% visually permeable by area and no more than 1.5 m high.
- Front fencing and balustrades shall be designed to complement the built form design.
- Colorbond and super six style fencing is not permitted.
- Closable louvre-style fins are not permitted for fencing abutting the street or public realm at ground level.



Visually permeable fencing to POS interfaces

#### Design Guidance:

- Fences should be specifically designed to integrate with the development to which they belong and enhance the adjacent public realm.
- Where the finished floor level is raised above the adjacent public realm, additional design and landscape treatments may be required to soften the boundary treatment to the public realm.
- The design of front setbacks (including the fencing and balustrades) needs to consider the privacy of residents to ensure residents are not reverting to the use of temporary fencing to provide privacy. Layering of these front spaces is promoted (e.g. through the use of more than one design element, such as semi-permeable openings, landscaped setback, change in level).
- Front fences, balustrades and gates should be truncated or reduced to no higher than 0.75m within 1.5m of where these structures adjoin vehicle access points where a driveway meets a public street and where two streets intersect.

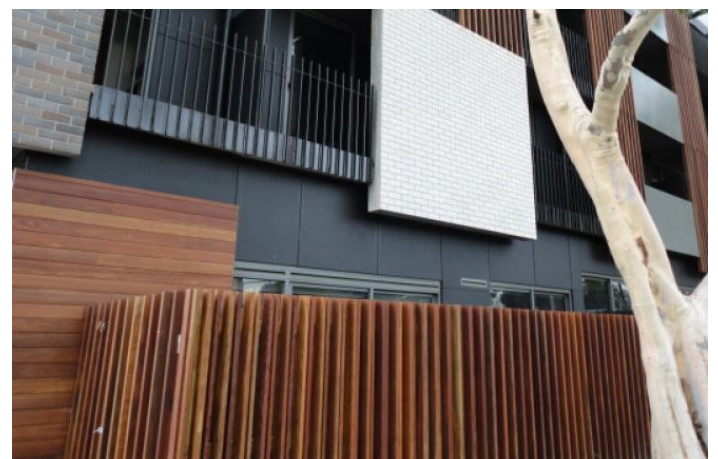

Fencing materials that are harmonious with the building design



## 8. ENVIRONMENTALLY SUSTAINABLE DEVELOPMENT

### 8.1 Climate Responsive Design

#### Objectives:

To provide high performance buildings that minimise energy use, conserve water, reduce waste and maximise comfort for occupants.

To ensure indoor and outdoor living areas have adequate access to sun during winter and effective shading in summer.

To ensure buildings operate at a high level of efficiency with dwellings each benefiting from a reduction in mechanical cooling and heating costs.

#### 8.1.1 Solar Design

#### Objectives:

Ensure that the built form is conceived in a way that allows good solar access to the public realm and adjacent buildings, whilst achieving comfortable internal and external environments for its occupants.

Incorporate passive solar design principles to optimise solar gain in winter and protection from heat gain in summer.

Building designs shall consider alternative opportunities for sunlight access to south facing apartments to limit impact to residents.

#### Development Controls:

- Minimum 70% of all residential apartments shall receive 2 hours direct sunlight to major living areas between 9am and 3pm mid-winter.
- Shadow studies are required on buildings over 10m in height.
- It is desirable for at least 70% of dwellings in multi-residential developments to have outdoor areas that benefit from a northerly aspect.
- A Site Plan shall be prepared to demonstrate solar design outcome for the DRP assessment.

### 8.1.2 Shading

#### Development Controls:

- Openings not shaded by appropriate eave overhangs shall be shaded with an appropriate shading device e.g. awning, louvre that enable winter sun penetration while keeping out summer sun.
- Glazing to habitable rooms facing east and west shall have vertical protection, such as louvered solar-shutters, blinds or screening devices.
- West-facing outdoor living areas shall be provided with shading devices to provide sun control.



## 8. ENVIRONMENTALLY SUSTAINABLE DEVELOPMENT

### 8.1.3 Ventilation

#### Development Controls:

- Maximise natural ventilation potential by orienting buildings and their openings to maximise air intake from the “windward” side of the building and by providing air outlets on the “leeward” side of the building.
- Use a range of appropriate apartment depths to ensure natural ventilation.
- Residential dwellings shall be designed to maximise cross ventilation by providing direct breeze paths for cooling and air circulation.
- A minimum of 60% of apartments shall be naturally cross ventilated. Some discretion may be permitted to apartments where a carpark is required to be sleeved by the building adjacent public realm.
- Glazing systems shall be installed with draught seals/weather stripping.

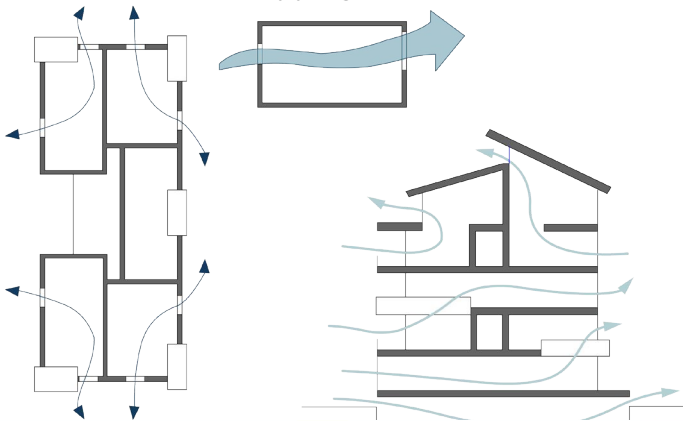

Ventilation can be achieved in combination with solar shading designs

### 8.2 Energy Efficiency

#### Objectives:

To provide high performance dwellings that minimises energy use and maximise the comfort for occupants

#### Development Controls:

(Required at Building Permit stage)

- The overall building shall achieve at least an average 5 Star NatHERS rating.
- Air-conditioning systems and other energy efficient appliances shall be minimum 5 star energy rating and sized appropriately for the space.
- A demonstrated highly energy efficient hot water system shall be installed (e.g. gas or solar boosted gas - centralised or local).

#### Design Guidance:

- Developer to consider producing a “Building/ Dwelling Management Manual”, or similar user-friendly document, to assist occupants to understand the intended performance of the building and specific operational requirements.
- Northern oriented solar collection panels are encouraged on roof areas for hot water heating and electricity generation.



Devices that enhance a building’s energy efficiency can also provide a strong architectural identity

## 8. ENVIRONMENTALLY SUSTAINABLE DEVELOPMENT

### 8.3 Water Efficiency

#### Objectives:

To reduce running costs and ensure more sustainable water use into the future.

#### 8.3.1 Plumbing Fixtures

##### Development Controls:

- a. Tapware and showers should exceed National Construction Code requirements for WELS star ratings by one star per fixture.

##### Design Guidance:

- a. Other water saving strategies should be investigated, such as provision for rainwater collection and reuse on site.

#### 8.3.2 Stormwater Management

##### Development Controls:

- a. All 1:100 year stormwater volumes shall be contained within the development site for multiple residential and mixed use developments.
- b. In accordance with AS/NZS 3500.3.

### 8.4 Lighting

#### Objectives:

Provide appropriate levels of lighting for both the private and public realm for safety, security and aesthetic appeal.

##### Development Controls:

- a. Lighting shall be provided under awnings to illuminate the footpath below.
- b. All outdoor lighting shall be directed downwards with no light spill above the horizontal plane.
- c. Front outdoor/security lights shall be operated via a timed motion sensor with manual over-ride.
- d. Rear outdoor areas adjacent to laneways shall be well lit and incorporate motion activated light fittings.

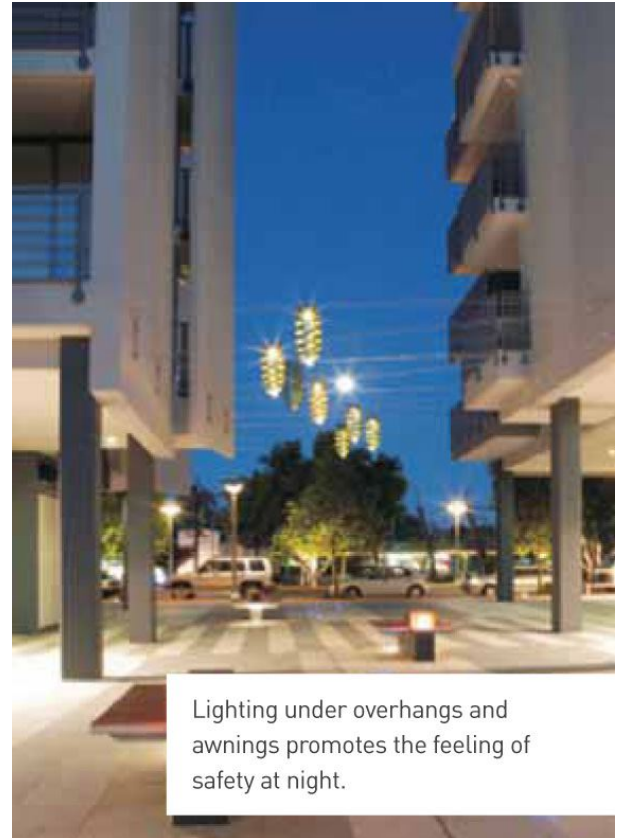

Lighting under overhangs and awnings promotes the feeling of safety at night.

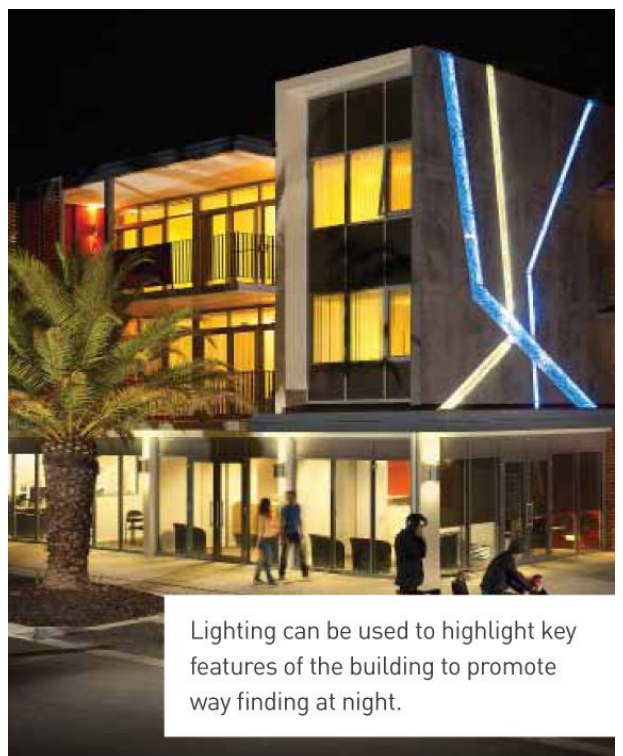

Lighting can be used to highlight key features of the building to promote way finding at night.



## 8. ENVIRONMENTALLY SUSTAINABLE DEVELOPMENT

### 8.5 Acoustics

#### Objectives:

To ensure that the noise challenges associated with mixed use precincts and buildings are mitigated to safeguard occupant amenity.

#### 8.5.1 Landuse Generated Noise

##### Development Controls:

- a. Prior to submission of a Development Application an acoustic assessment shall be prepared in accordance with City of Cockburn Noise Attenuation Local Planning Policy requirements for all development proposals within Cockburn Central West.

### 8.5.2 Road Noise

#### Development Controls:

- a. Prior to submission of a Development Application an acoustic assessment shall be prepared in accordance with City of Cockburn Local Planning Policy LPP1.12 requirements for buildings on lots affected by noise from Beeliar Drive, Midgegooroo Avenue and North Lake Road as identified in Herring Storer's Acoustic Assessment (November 2014).



Mixed landuse generated noise considerations



Adjacent recreational generated noise considerations for residents



## 9. LANDSCAPE DESIGN

### Objectives:

To create an attractive landscape environment that is complementary to the wider precinct while allowing for variation between developments.

To ensure that the built form integrates with the surrounding urban context, streets, parks and neighbouring properties.

To create attractive private realm areas that are respectful of adjacent public realm, including public open space, public accessway or streetscapes, and present a landscape character cohesive with the wider precinct aesthetic.

Achieve inviting and comfortable external environments that are well connected to the built form.

Creation of a landscape that enhances the biodiversity and habitat values of the precinct.

Use native flowering species as part of introduced landscapes to provide food and habitat opportunities for birds and insects.

To improve residential amenity, local microclimate and promote management of water and air quality through the growth of healthy trees in deep root zones on development sites.



Example of deep root zone benefits

### 9.1 Deep Root Zones

#### Development Controls:

- For development incorporating residential landuse at the ground floor, a minimum 25% of the sites open space requirement shall be provided as deep root zone.
- A deep root zone shall not be covered by buildings or structures within a development. They can be co-located with communal open space but exclude all impervious surfaces.
- Deep root zones shall be located to allow for the mature development of trees with large canopies.
- Weed potential plants shall be avoided.
- The use of tree species which encourage foraging and roosting by birds is encouraged.
- Where the deep root zone controls are not achievable on a site due to the location or building typology, acceptable stormwater management shall be achieved and alternate forms of planting provided such as on structure.
- Species selection to be of an appropriate scale to the building.

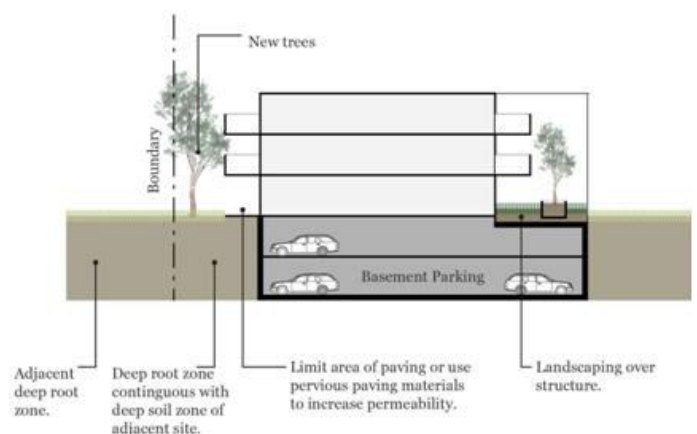

Figure 9.1 Example of deep root zone in section

## 9. LANDSCAPE DESIGN

### 9.2 Hardscaping

#### Development Controls:

- Hard stand areas shall be designed so that heat retention and re-radiation is minimised so the increase in ambient air temperature around buildings is contained.
- Minimise the extent of paving, or use permeable paving, to increase stormwater permeability.
- Vehicular surfaces, pedestrian entries, external foyer spaces and ground floor setback areas which are accessible to the public shall be treated with materials and colours sympathetic to those used in the adjacent public realm. This may include, but not limited to, paving, edging, walling, balustrades, handrails, steps, fencing, plant species, furniture, lighting and signage.
- Publicly-accessible areas shall be designed to suit individuals requiring universal access (IRUA).
- Damage to public realm works shall be rectified by the developer at the developer's expense to match pre-existing works.

#### Design Guidance

- Any general waste collection space to accommodate various bins for recyclable waste and other materials, or as required by the City of Cockburn, should be considered as part of any overall landscape plan.

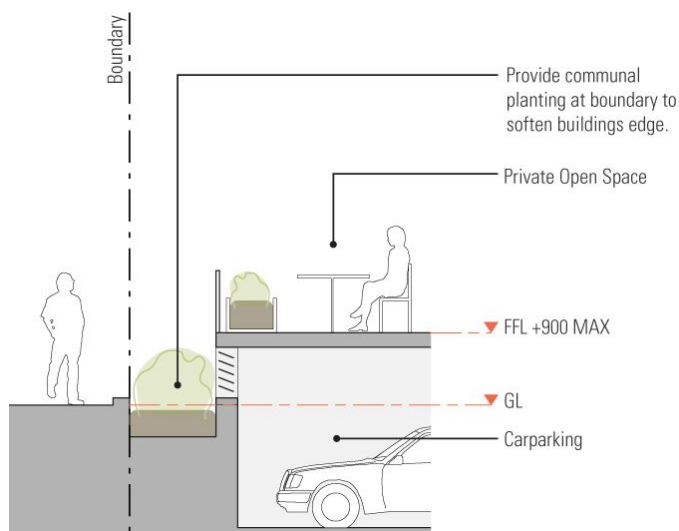

Figure 9.2 Example of landscaping used to mitigate raised building interface to street



Example of tree planting opportunities in front setback and benefits to streetscape amenity

## 9. LANDSCAPE DESIGN

### 9.3 Softscaping

#### Development Controls:

- a. A landscape concept design is required at design review meeting with the DRP.
- b. A landscaping plan shall be submitted detailing plant types, number, irrigation and mulch type for Building Permit.
- c. Landscaping will be designed with a view to CPTED principles and allow development to take advantage of views over open space while assisting with creation of an attractive urban edge with landscaping on verge and near-verge areas to soften the appearance of buildings and provide shading.
- d. At least 50% of the proposed plants shall be Western Australian native species.
- e. Use of predominantly low understorey shrub and groundcover species of less than 1 metre mature height.
- f. Use of single-trunk tree species with a mature canopy starting point higher than 2.5 metres, where pedestrian access and uninterrupted sightlines are required.
- g. Planting areas should be designed for full coverage.
- h. Species selection and planting themes shall respond to local conditions and relate to the character, scale and proportions of the streetscape and built form.
- i. Avoid the use of continuous lengths of blank walls on sites where outdoor space (private or communal) is raised over 0.5m above street level (or open space) by placing planting to soften the edges and reduce their apparent scale.



Reduced street setbacks still offer landscaped potential

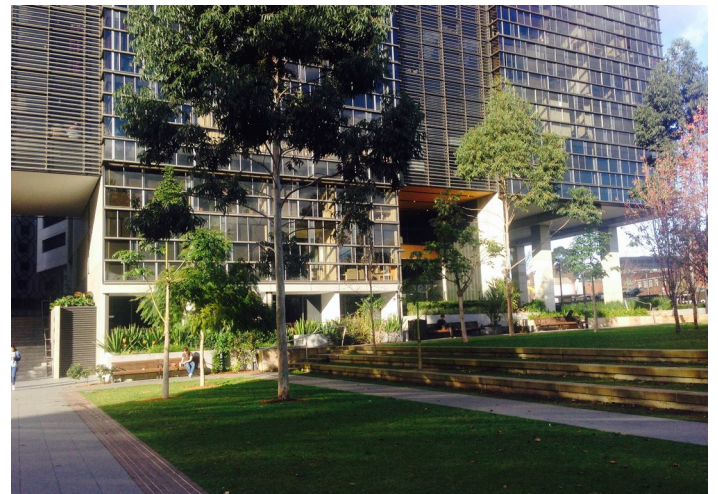

Planting at the building's ground level enhances the interface with the public realm



## 9. LANDSCAPE DESIGN

### 9.4 Water Efficiency and Maintenance

#### Development Controls:

- a. An irrigation plan shall be included as part of the Landscape Plan for Building Approval.
- b. The use of water efficient irrigation shall be installed for all garden beds.
- c. Private water bores are not permitted.
- d. Spray irrigation may be used on turf areas only.
- e. An automatic irrigation system including a rain sensor shall be installed that adheres to current Water Corporation water usage standards and restrictions.
- f. Developments shall allow water to permeate the ground surface by maximising permeable ground surface treatment such as gravel, crushed stone, permeable paving or pavers on a sand base.

### 9.5 Construction Zone

#### Development Controls:

- a. A 'construction zone' of 2.0m width has been allowed for in the design of the public open space areas. This zone is available for temporary use by the building developer to facilitate the building construction process. At the end of the construction process, the land owner will be responsible for landscape construction within the construction zone.
- b. Final landscaping of the construction zone shall be completed to the satisfaction of the City of Cockburn.
- c. Locations and extent of Construction Zone are detailed on the Site Specific Building Requirements (section 10).



Hard and soft landscaping can provide water efficient outcomes



# Part 3

## Site Specific Provisions

## 10. SITE SPECIFIC BUILDING REQUIREMENTS

The site specific building requirements contain controls and details particular to individual lots or groups of lots - 'sites'.

These sites have been configured to consider development outcomes with the possible amalgamation by landowners in the future.



Site Location Key

# 10. SITE SPECIFIC BUILDING REQUIREMENTS

\* to be read in conjunction with relevant General Provisions.

## SITE 1



Location:

Key Controls	Location	Requirement
<b>Setbacks</b>		
<b>Basement:</b>	All boundaries:	Nil permitted
<b>Ground Floor – podium*:</b> (measured from lot boundary)	North Lake Road:	3.0m minimum/no maximum <sup>1</sup>
	Honour Way:	3.0m average/no maximum
	Legacy Way:	Nil minimum/3.0m maximum - where retail landuse
	Public Utility Reserve:	Nil permitted/no maximum <sup>2</sup>
<b>Above podium:</b> (measured from building edge)	All roads:	3.0m minimum/no maximum
	Public Utility Reserve:	Nil permitted/no maximum <sup>2</sup>
<b>Top two storeys:</b> (for buildings in excess of 8 storeys – measured from building edge)	All roads:	2.0m minimum/no maximum
	Public Utility Reserve:	Nil permitted/no maximum <sup>2</sup>
<b>Building Height</b>	Legacy Way:	3 storey/5 storey height maximum where communal open space zone located
<b>Noise Attenuation</b>	Lots adjacent North Lake Road may be affected by noise. Development applications must be accompanied by an acoustic report addressing all relevant requirements.	
<b>Service Infrastructure</b>	<sup>1</sup> Development setback subject to ATCO guidelines requirements for any works within 15m of the High Pressure Gas Main. Developers should satisfy themselves of detailed requirements.	
	<sup>2</sup> Development setback subject to infrastructure specific requirements. Developers should satisfy themselves of detailed requirements.	

\* Refer to performance based bonus criteria outlined at section 6.3.



Site Diagram

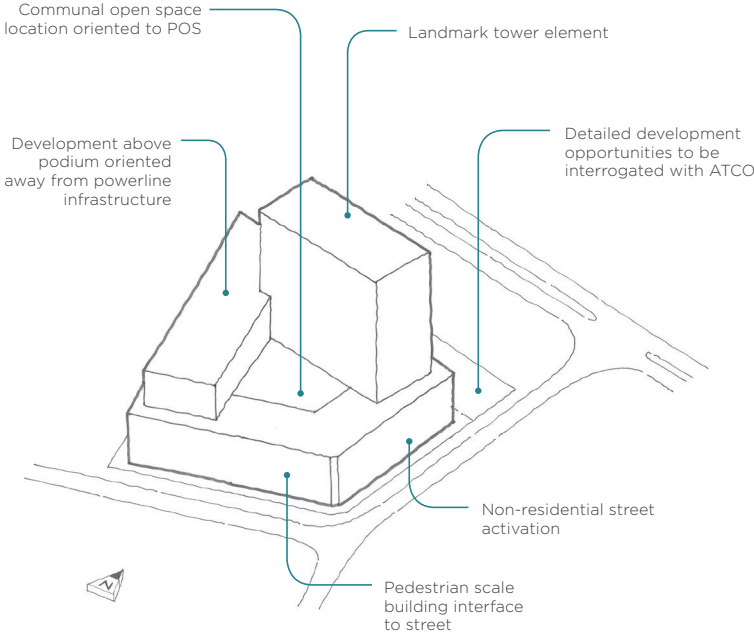

Indicative Principles Diagram

**LEGEND**

**Building Zones**

- Public Open Space Interface Treatment Requirements (refer sections 6.5, 7.2, 7.3, 7.7 & 7.9)
- 4st Minimum 4 storeys (no max)
- ★ Landmark Building (specific corner design requirements, refer 6.5)
- ▽ Priority Facade - Building Orientation
- Communal Private Open Space Priority Zone (located on podium)
- Preferred (Priority) location for building height over 5 storeys
- View corridor/building break requirement at ground level
- Construction Zone
- Public Utility Buffer -15m (ATCO Gas)
- Service Infrastructure (approx. alignment)

**Landuse**

- Mandatory Non-Residential Landuse - Ground Floor
- Non-Residential Landuses Encouraged - Ground Floor

**Movement**

- No Vehicle Access Permitted
- Vehicle Access Permitted where the access point is not dominant within the building facade

Site Diagram Legend

# 10. SITE SPECIFIC BUILDING REQUIREMENTS

\* to be read in conjunction with relevant General Provisions.

## SITE 2

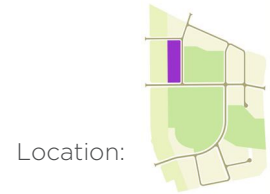

Key Controls	Location	Requirement
<b>Setbacks</b>		
<b>Basement:</b>	All boundaries:	Nil permitted
<b>Ground Floor – podium*:</b> (measured from lot boundary)	Honour Way, Legacy Way and Veterans Parade:	3.0m average/no maximum
	Legacy Way and Veterans Parade:	Nil minimum/3.0m maximum - where adaptable building design criteria met
	Public Utility Reserve:	Nil permitted/no maximum <sup>1</sup>
<b>Above podium:</b> (measured from building edge)	All roads:	3.0m minimum/no maximum
	Public Utility Reserve:	Nil permitted/no maximum <sup>1</sup>
<b>Top two storeys:</b> (for buildings in excess of 8 storeys - measured from building edge)	All roads:	2.0m minimum/no maximum
	Public Utility Reserve:	Nil permitted/no maximum <sup>1</sup>
<b>Building Height</b>	Legacy Way:	3 storey/5 storey height maximum where communal open space zone located
	Legacy Way/Veterans Parade corner:	4 storey minimum building height required within 20.0m of corner lot truncation
<b>Building Break</b>	The building design shall include a minimum of one physical break to the podium facade at boundary indicated.	
<b>Service Infrastructure</b>	<sup>1</sup> Development setback subject to infrastructure specific requirements. Developers should satisfy themselves of detailed requirements.	

\* Refer to performance based bonus criteria outlined at section 6.3.

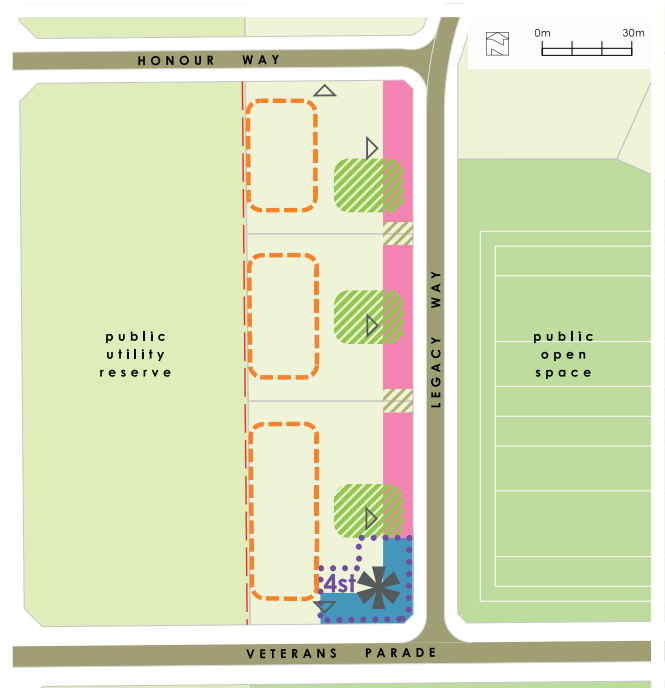

Site Diagram

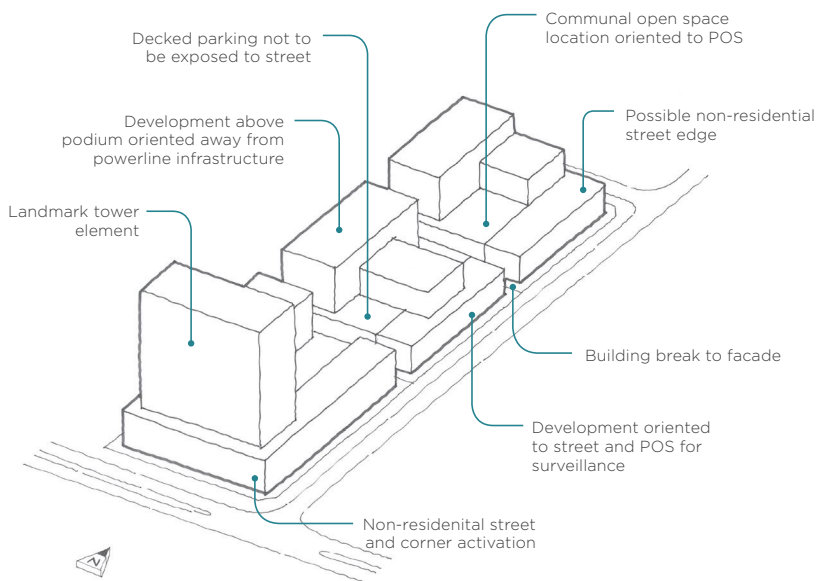

Indicative Principles Diagram

### LEGEND

#### Building Zones

- Public Open Space Interface Treatment Requirements (refer sections 6.5, 7.2, 7.3, 7.7 & 7.9)
- 4st Minimum 4 storeys (no max)
- ★ Landmark Building (specific corner design requirements, refer 6.5)
- ▽ Priority Facade - Building Orientation
- Communal Private Open Space Priority Zone (located on podium)
- Preferred (Priority) location for building height over 5 storeys
- View corridor/building break requirement at ground level
- Construction Zone
- Public Utility Buffer -15m (ATCO Gas)
- Service Infrastructure (approx. alignment)

#### Landuse

- Mandatory Non-Residential Landuse - Ground Floor
- Non-Residential Landuses Encouraged - Ground Floor

#### Movement

- No Vehicle Access Permitted
- Vehicle Access Permitted where the access point is not dominant within the building facade

Site Diagram Legend



# 10. SITE SPECIFIC BUILDING REQUIREMENTS

\* to be read in conjunction with relevant General Provisions.

## SITE 3

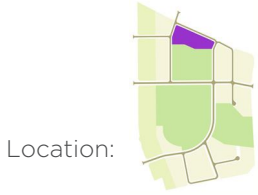

Key Controls	Location	Requirement
<b>Setbacks</b>		
<b>Basement:</b>	All boundaries:	Nil permitted
<b>Ground Floor – podium*:</b> (measured from lot boundary)	All roads	3.0m average/no maximum
	Public Open Space frontage:	3.0m minimum/no maximum
<b>Above podium:</b> (measured from building edge)	All roads:	3.0m minimum/no maximum
	Public Open Space frontage:	Determined subject to overshadowing considerations
<b>Top two storeys:</b> (for buildings in excess of 8 storeys – measured from building edge)	All roads:	2.0m minimum/no maximum
	Public Open Space frontage:	2.0m minimum/no maximum
<b>Building Height</b>	Public Open Space frontage:	3 storey/5 storey height maximum where communal open space zone located
		Building tower element restrictions apply – refer general provisions
<b>Noise Attenuation</b>	Lots adjacent North Lake Road may be affected by noise. Development applications must be accompanied by an acoustic report addressing all relevant requirements.	

\* Refer to performance based bonus criteria outlined at section 6.3.

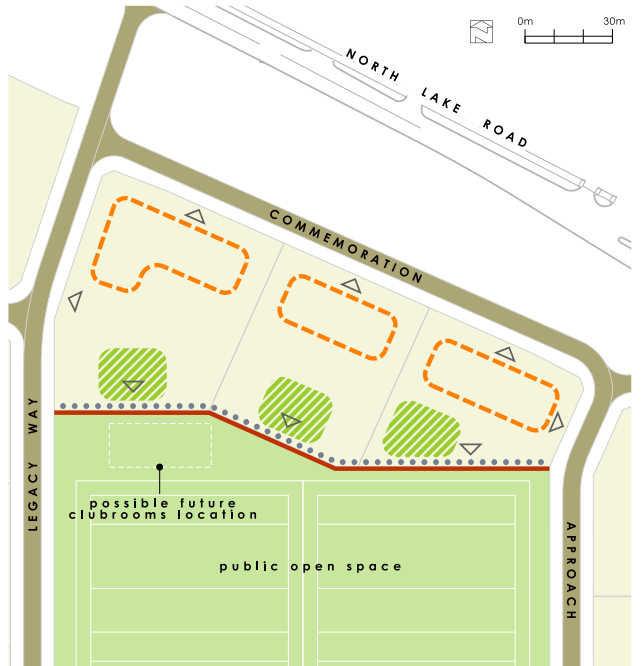

Site Diagram

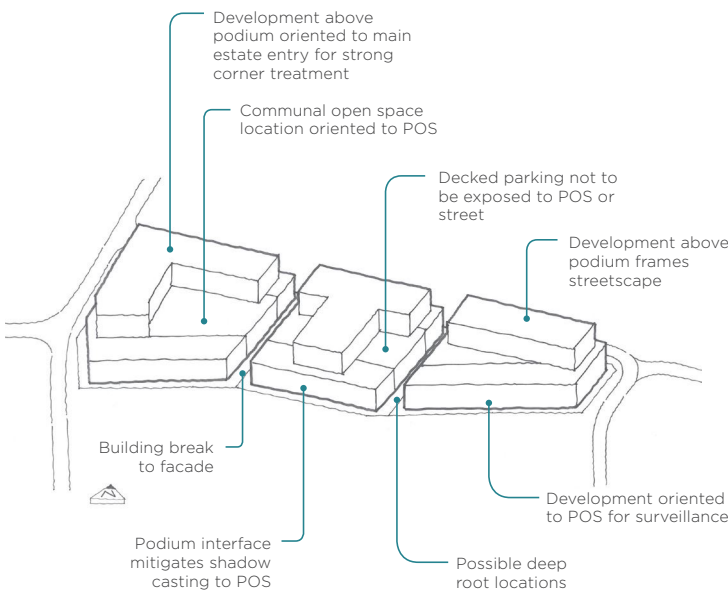

Indicative Principles Diagram

**LEGEND**

**Building Zones**

- Public Open Space Interface Treatment Requirements (refer sections 6.5, 7.2, 7.3, 7.7 & 7.9)
- 4st Minimum 4 storeys (no max)
- ✳ Landmark Building (specific corner design requirements, refer 6.5)
- ▽ Priority Facade - Building Orientation
- Communal Private Open Space Priority Zone (located on podium)
- Preferred (Priority) location for building height over 5 storeys
- View corridor/building break requirement at ground level
- Construction Zone
- Public Utility Buffer -15m (ATCO Gas)
- Service Infrastructure (approx. alignment)

**Landuse**

- Mandatory Non-Residential Landuse - Ground Floor
- Non-Residential Landuses Encouraged - Ground Floor

**Movement**

- No Vehicle Access Permitted
- Vehicle Access Permitted where the access point is not dominant within the building facade

Site Diagram Legend

# 10. SITE SPECIFIC BUILDING REQUIREMENTS

\* to be read in conjunction with relevant General Provisions.

## SITE 4

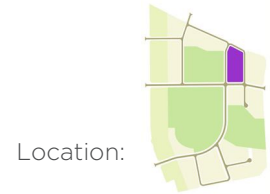

Key Controls	Location	Requirement
<b>Setbacks</b>		
<b>Basement:</b>	All boundaries:	Nil permitted
<b>Ground Floor – podium*:</b> (measured from lot boundary)	All roads and laneways:	3.0m average/no maximum
	Commemoration Approach and Veterans Parade:	Nil minimum/3.0m maximum - where adaptable building design criteria met
<b>Above podium:</b> (measured from building edge)	All roads:	3.0m minimum/no maximum
<b>Top two storeys:</b> (for buildings in excess of 8 storeys - measured from building edge)	All roads:	2.0m minimum/no maximum
<b>Building Break</b>	The building design shall include a minimum of one physical break to the podium facade at boundary indicated.	
<b>Building Height</b>	Commemoration Approach:	3 storey/5 storey height maximum where communal open space zone located
	Commemoration Approach/Veterans Parade corner:	4 storey minimum building height required within 20.0m of corner lot truncation
<b>Noise Attenuation</b>	Lots adjacent North Lake Road or located in close proximity to the aquatic facility may be affected by noise. Development applications must be accompanied by an acoustic report addressing all relevant requirements.	

\* Refer to performance based bonus criteria outlined at section 6.3.



Site Diagram

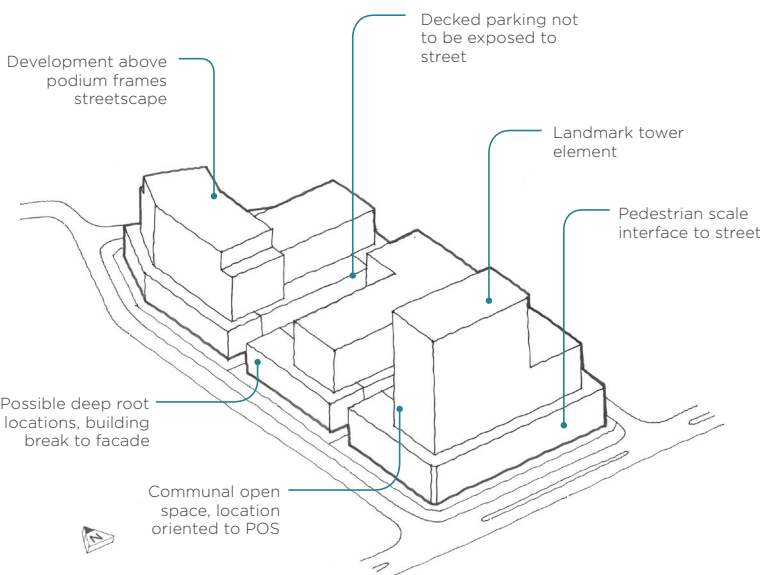

Indicative Principles Diagram

### LEGEND

#### Building Zones

- Public Open Space Interface Treatment Requirements (refer sections 6.5, 7.2, 7.3, 7.7 & 7.9)
- 4st Minimum 4 storeys (no max)
- ★ Landmark Building (specific corner design requirements, refer 6.5)
- ▽ Priority Facade - Building Orientation
- Communal Private Open Space Priority Zone (located on podium)
- Preferred (Priority) location for building height over 5 storeys
- View corridor/building break requirement at ground level
- Construction Zone
- Public Utility Buffer -15m (ATCO Gas)
- Service Infrastructure (approx. alignment)

#### Landuse

- Mandatory Non-Residential Landuse - Ground Floor
- Non-Residential Landuses Encouraged - Ground Floor

#### Movement

- No Vehicle Access Permitted
- Vehicle Access Permitted where the access point is not dominant within the building facade

Site Diagram Legend

# 10. SITE SPECIFIC BUILDING REQUIREMENTS

\* to be read in conjunction with relevant General Provisions.

## SITE 5



Location:

Key Controls	Location	Requirement
<b>Setbacks</b>		
<b>Basement:</b>	All boundaries:	Nil permitted
<b>Ground Floor – podium*:</b> (measured from lot boundary)	North Lake Road	3.0m minimum/no maximum - measured from infrastructure alignment <sup>1</sup>
	All remaining roads	3.0m average/no maximum
<b>Above podium:</b> (measured from building edge)	All roads:	3.0m minimum/no maximum
<b>Top two storeys:</b> (for buildings in excess of 8 storeys - measured from building edge)	All roads:	2.0m minimum/no maximum
<b>Noise Attenuation</b>	Lots adjacent North Lake Road and Midgegooroo Avenue may be affected by noise. Development applications must be accompanied by an acoustic report addressing all relevant requirements.	
<b>Service Infrastructure</b>	<sup>1</sup> Development setback subject to ATCO guidelines requirements for any works within 15m of the High Pressure Gas Main. Developers should satisfy themselves of detailed requirements.	

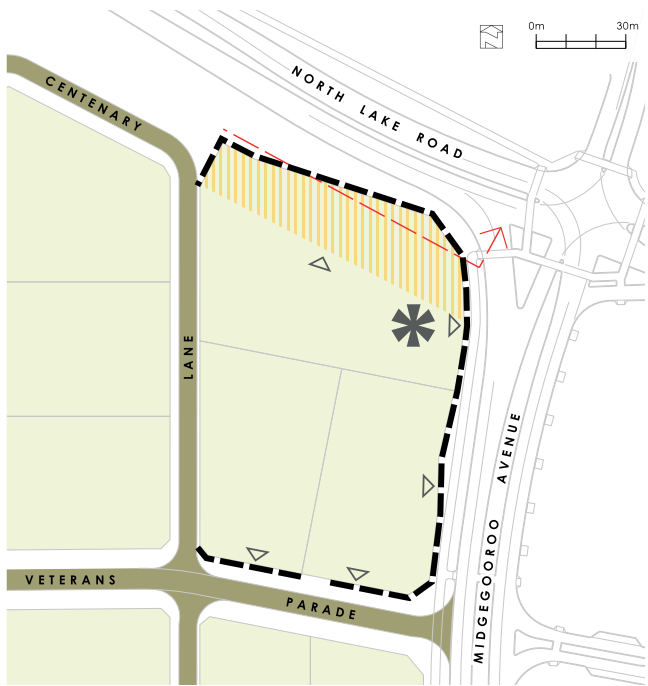

Site Diagram

\* Refer to performance based bonus criteria outlined at section 6.3.

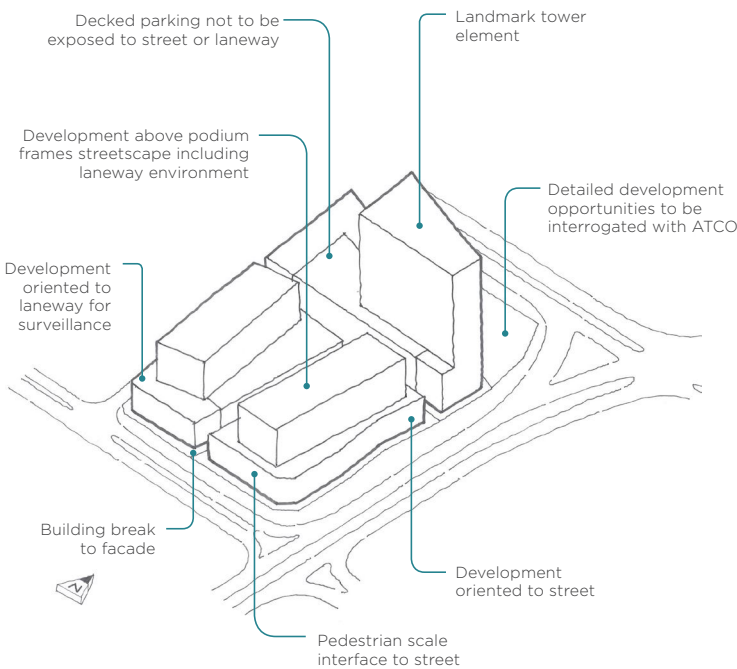

Indicative Principles Diagram

- LEGEND**
- Building Zones**
- Public Open Space Interface Treatment Requirements (refer sections 6.5, 7.2, 7.3, 7.7 & 7.9)
  - 4st Minimum 4 storeys (no max)
  - ✱ Landmark Building (specific corner design requirements, refer 6.5)
  - ▽ Priority Facade - Building Orientation
  - Green hatched box Communal Private Open Space Priority Zone (located on podium)
  - Orange dashed box Preferred (Priority) location for building height over 5 storeys
  - Yellow hatched box View corridor/building break requirement at ground level
  - Red hatched box Construction Zone
  - Yellow vertical lines Public Utility Buffer -15m (ATCO Gas)
  - Red arrow Service Infrastructure (approx. alignment)
- Landuse**
- Blue box Mandatory Non-Residential Landuse - Ground Floor
  - Pink box Non-Residential Landuses Encouraged - Ground Floor
- Movement**
- Black dashed line No Vehicle Access Permitted
  - Black dotted line Vehicle Access Permitted where the access point is not dominant within the building facade

Site Diagram Legend

# 10. SITE SPECIFIC BUILDING REQUIREMENTS

\* to be read in conjunction with relevant General Provisions.

## SITE 6

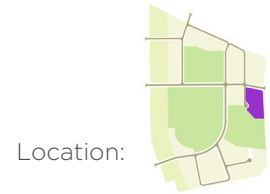

Key Controls	Location	Requirement
<b>Setbacks</b>		
<b>Basement:</b>	All boundaries:	Nil permitted
<b>Ground Floor – podium*:</b> (measured from lot boundary)	All roads	3.0m average/no maximum
	Public Open Space frontage:	3.0m minimum/no maximum
<b>Above podium:</b> (measured from building edge)	All roads:	3.0m minimum/no maximum
	Public Open Space frontage:	Determined subject to overshadowing considerations
<b>Top two storeys:</b> (for buildings in excess of 8 storeys – measured from building edge)	All roads:	2.0m minimum/no maximum
	Public Open Space frontage:	2.0m minimum/no maximum
<b>Building Height</b>	Public Open Space frontage:	Building tower element restrictions apply – refer general provisions
<b>Noise Attenuation</b>	Lots adjacent Midgegooroo Avenue may be affected by noise. Development applications must be accompanied by an acoustic report addressing all relevant requirements.	

\* Refer to performance based bonus criteria outlined at section 6.3.

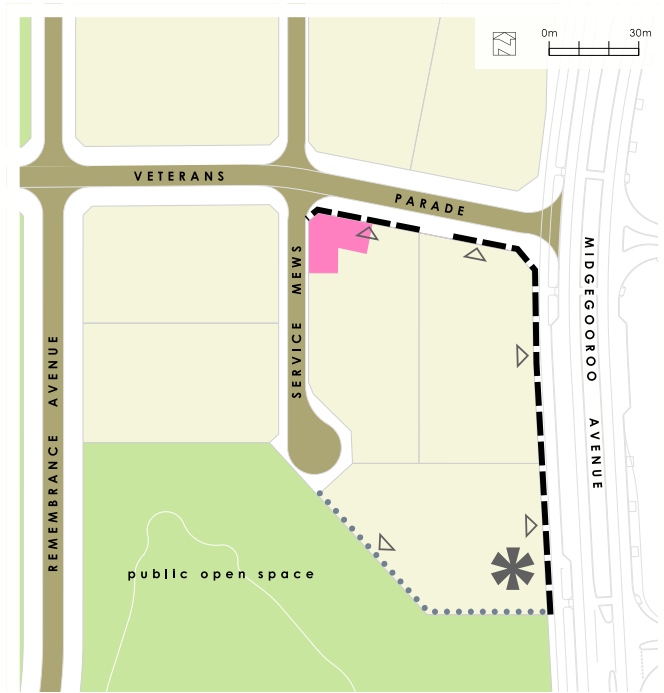

Site Diagram

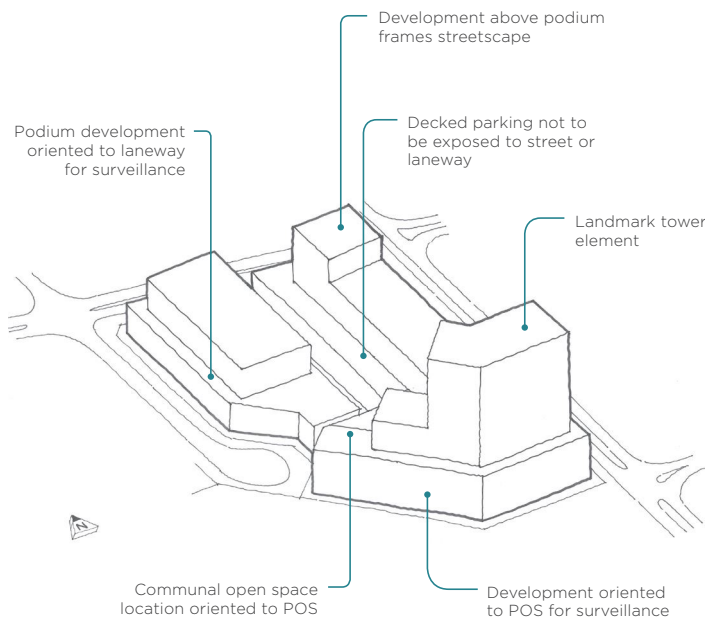

Indicative Principles Diagram

### LEGEND

#### Building Zones

- Public Open Space Interface Treatment Requirements (refer sections 6.5, 7.2, 7.3, 7.7 & 7.9)
- 4st Minimum 4 storeys (no max)
- ★ Landmark Building (specific corner design requirements, refer 6.5)
- ▽ Priority Facade - Building Orientation
- Communal Private Open Space Priority Zone (located on podium)
- Preferred (Priority) location for building height over 5 storeys
- View corridor/building break requirement at ground level
- Construction Zone
- Public Utility Buffer -15m (ATCO Gas)
- Service Infrastructure (approx. alignment)

#### Landuse

- Mandatory Non-Residential Landuse - Ground Floor
- Non-Residential Landuses Encouraged - Ground Floor

#### Movement

- No Vehicle Access Permitted
- Vehicle Access Permitted where the access point is not dominant within the building facade

Site Diagram Legend



# 10. SITE SPECIFIC BUILDING REQUIREMENTS

\* to be read in conjunction with relevant General Provisions.

## SITE 7

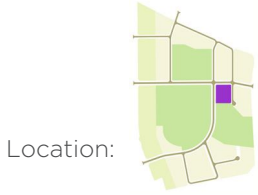

Key Controls	Location	Requirement
<b>Setbacks</b>		
<b>Basement:</b>	All boundaries:	Nil permitted
<b>Ground Floor – podium*:</b> (measured from lot boundary)	All roads and laneways:	3.0m average/no maximum
	Remembrance Avenue and Veterans Parade:	Nil minimum/3.0m maximum - where adaptable building design criteria met
	Public Open Space frontage:	3.0m minimum/no maximum
<b>Above podium:</b> (measured from building edge)	All roads:	3.0m minimum/no maximum
	Public Open Space frontage:	Determined subject to overshadowing considerations
<b>Top two storeys:</b> (for buildings in excess of 8 storeys - measured from building edge)	All roads:	2.0m minimum/no maximum
	Public Open Space frontage:	2.0m minimum/no maximum
<b>Building Break</b>	The building design shall include a minimum of one physical break to the podium facade at boundary indicated.	
<b>Building Height</b>	Remembrance Avenue/ Veterans Parade corner:	4 storey minimum building height required within 20.0m of corner lot truncation
	Public Open Space frontage:	Building tower element restrictions apply - refer general provisions
<b>Noise Attenuation</b>	Lots in close proximity to the aquatic facility may be affected by noise. Development applications must be accompanied by an acoustic report addressing all relevant requirements.	

\* Refer to performance based bonus criteria outlined at section 6.3.

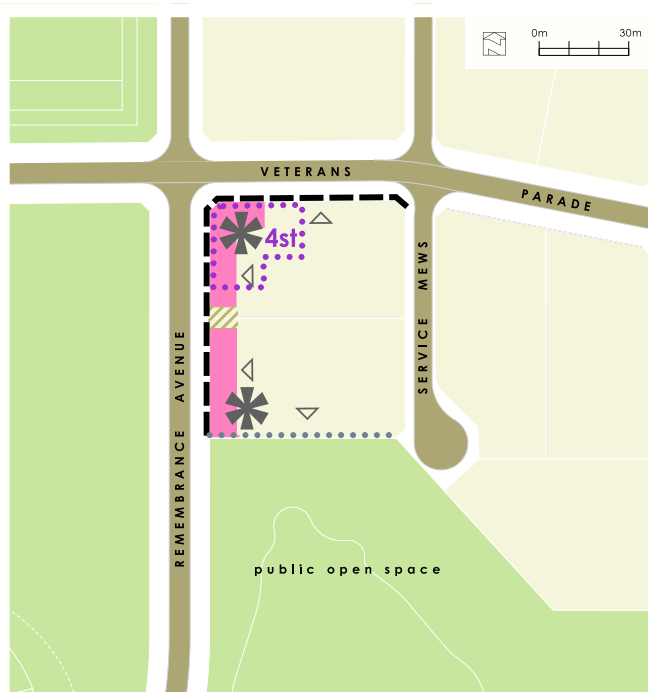

Site Diagram

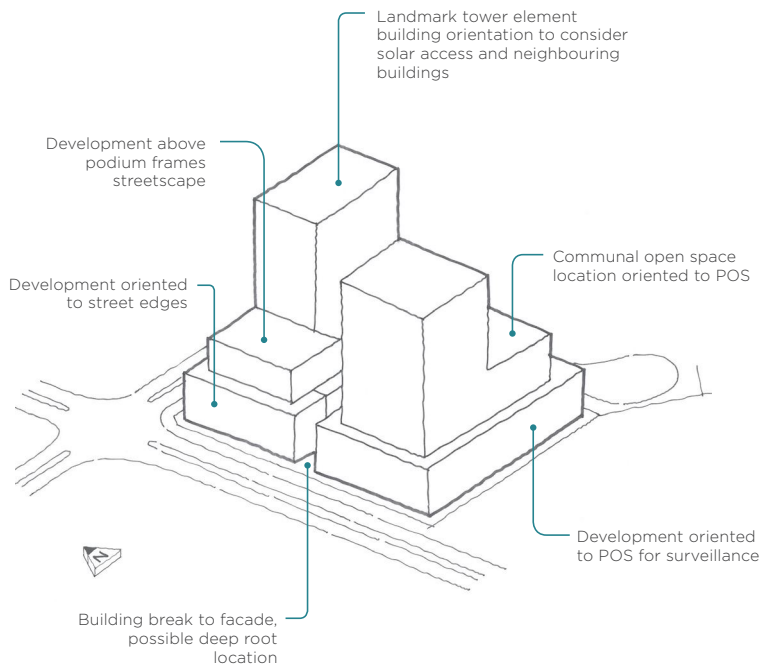

Indicative Principles Diagram

**LEGEND**

**Building Zones**

- Public Open Space Interface Treatment Requirements (refer sections 6.5, 7.2, 7.3, 7.7 & 7.9)
- 4st Minimum 4 storeys (no max)
- ✱ Landmark Building (specific corner design requirements, refer 6.5)
- ▽ Priority Facade - Building Orientation
- Communal Private Open Space Priority Zone (located on podium)
- Preferred (Priority) location for building height over 5 storeys
- View corridor/building break requirement at ground level
- Construction Zone
- Public Utility Buffer -15m (ATCO Gas)
- Service Infrastructure (approx. alignment)

**Landuse**

- Mandatory Non-Residential Landuse - Ground Floor
- Non-Residential Landuses Encouraged - Ground Floor

**Movement**

- No Vehicle Access Permitted
- Vehicle Access Permitted where the access point is not dominant within the building facade

Site Diagram Legend

# 10. SITE SPECIFIC BUILDING REQUIREMENTS

\* to be read in conjunction with relevant General Provisions.

## SITE 8

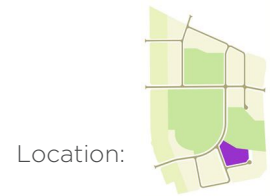

Key Controls	Location	Requirement
<b>Setbacks</b>		
<b>Basement:</b>	All boundaries:	Nil permitted
<b>Ground Floor – podium*:</b> (measured from lot boundary)	All roads and PAW:	3.0m average/no maximum
	Remembrance Avenue and Road A:	Nil minimum/3.0m maximum - where adaptable building design criteria met
<b>Above podium:</b> (measured from building edge)	Public Open Space frontage:	3.0m minimum/no maximum
	All roads and PAW:	3.0m minimum/no maximum
<b>Top two storeys:</b> (for buildings in excess of 8 storeys - measured from building edge)	Public Open Space frontage:	3.0m minimum/no maximum
	All roads and PAW:	2.0m minimum/no maximum
<b>Building Break</b>	Public Open Space frontage:	2.0m minimum/no maximum
	The building design shall include a minimum of one physical break to the podium facade at boundary indicated.	
<b>Building Height</b>	Public Open Space frontage:	Building tower element restrictions apply - refer general provisions

\* Refer to performance based bonus criteria outlined at section 6.3.

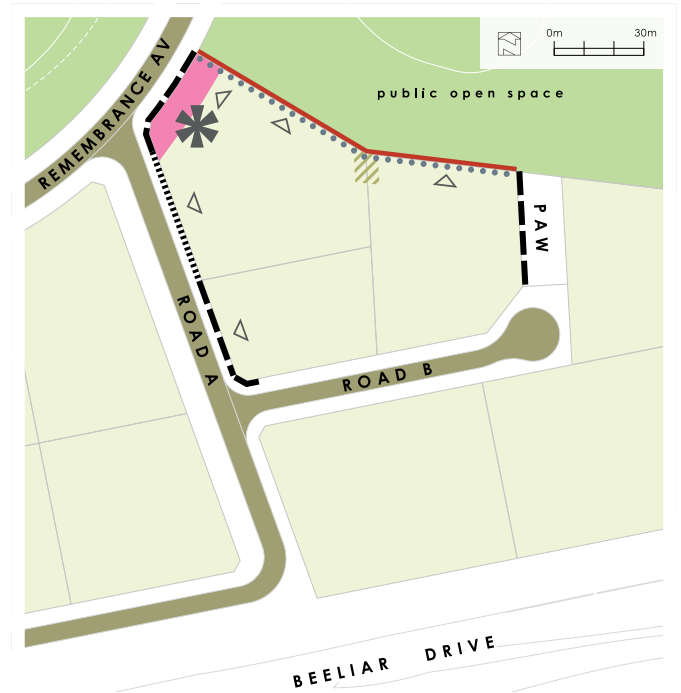

Site Diagram

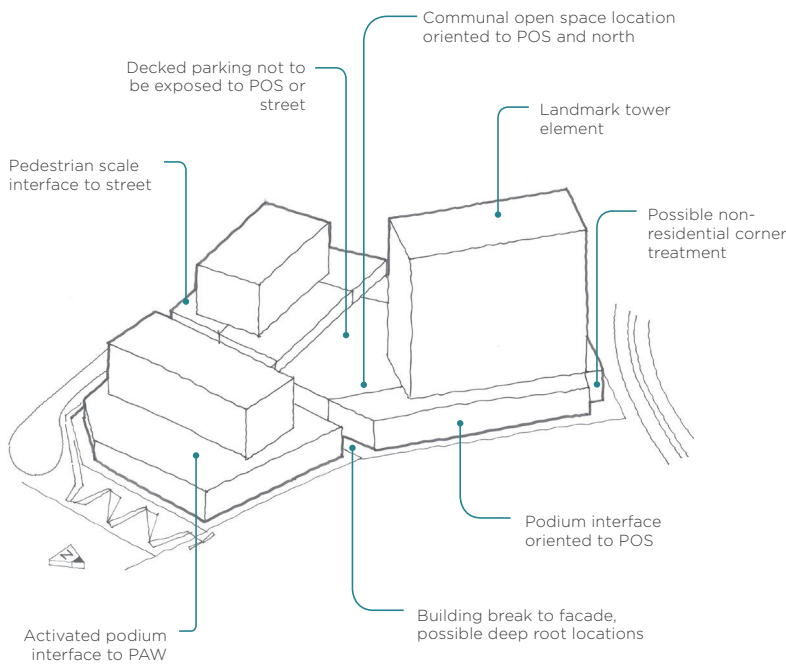

Indicative Principles Diagram

### LEGEND

#### Building Zones

- Public Open Space Interface Treatment Requirements (refer sections 6.5, 7.2, 7.3, 7.7 & 7.9)
- 4st Minimum 4 storeys (no max)
- ★ Landmark Building (specific corner design requirements, refer 6.5)
- ▽ Priority Facade - Building Orientation
- Communal Private Open Space Priority Zone (located on podium)
- Preferred (Priority) location for building height over 5 storeys
- View corridor/building break requirement at ground level
- Construction Zone
- Public Utility Buffer -15m (ATCO Gas)
- Service Infrastructure (approx. alignment)

#### Landuse

- Mandatory Non-Residential Landuse - Ground Floor
- Non-Residential Landuses Encouraged - Ground Floor

#### Movement

- No Vehicle Access Permitted
- Vehicle Access Permitted where the access point is not dominant within the building facade

Site Diagram Legend

# 10. SITE SPECIFIC BUILDING REQUIREMENTS

\* to be read in conjunction with relevant General Provisions.

## SITE 9

Location: 

Key Controls	Location	Requirement
<b>Setbacks</b>		
<b>Basement:</b>	All boundaries:	Nil permitted
<b>Ground Floor – podium*:</b> (measured from lot boundary)	All roads and PAW:	3.0m average/no maximum
	Midgegooroo Avenue and Beelias Drive:	Nil minimum/3.0m maximum - where adaptable building design criteria met
	Public Open Space frontage:	3.0m minimum/no maximum
<b>Above podium:</b> (measured from building edge)	All roads and PAW:	3.0m minimum/no maximum
	Public Open Space frontage:	3.0m minimum/no maximum
<b>Top two storeys:</b> (for buildings in excess of 8 storeys - measured from building edge)	All roads and PAW:	2.0m minimum/no maximum
	Public Open Space frontage:	2.0m minimum/no maximum
<b>Building Height</b>	Public Open Space frontage:	Building tower element restrictions apply - refer general provisions
<b>Noise Attenuation</b>	Lots adjacent Midgegooroo Avenue and Beelias Drive may be affected by noise. Development applications must be accompanied by an acoustic report addressing all relevant requirements.	

\* Refer to performance based bonus criteria outlined at section 6.3.

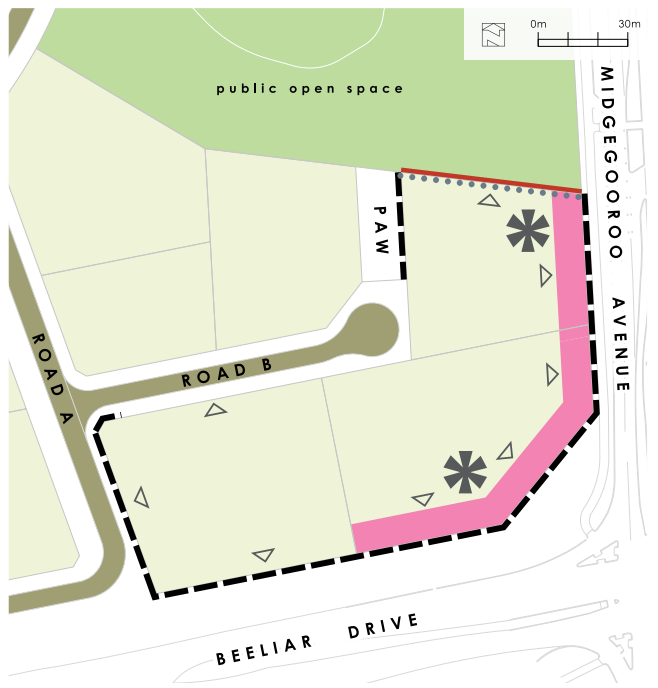

Site Diagram

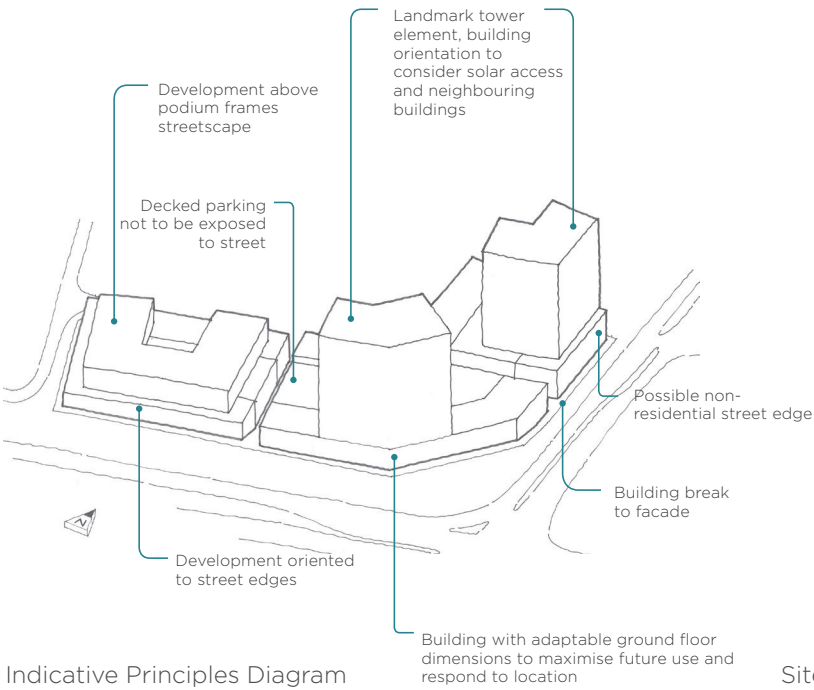

Indicative Principles Diagram

- LEGEND**
- Building Zones**
- Public Open Space Interface Treatment Requirements (refer sections 6.5, 7.2, 7.3, 7.7 & 7.9)
  - 4st Minimum 4 storeys (no max)
  - ✱ Landmark Building (specific corner design requirements, refer 6.5)
  - ▽ Priority Facade - Building Orientation
  - ▨ Communal Private Open Space Priority Zone (located on podium)
  - ▨ Preferred (Priority) location for building height over 5 storeys
  - ▨ View corridor/building break requirement at ground level
  - ▨ Construction Zone
  - ▨ Public Utility Buffer -15m (ATCO Gas)
  - ← Service Infrastructure (approx. alignment)
- Landuse**
- ▨ Mandatory Non-Residential Landuse - Ground Floor
  - ▨ Non-Residential Landuses Encouraged - Ground Floor
- Movement**
- No Vehicle Access Permitted
  - ⋯ Vehicle Access Permitted where the access point is not dominant within the building facade

Site Diagram Legend

# 10. SITE SPECIFIC BUILDING REQUIREMENTS

\* to be read in conjunction with relevant General Provisions.

## SITE 10

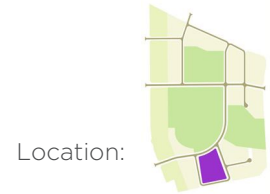

Key Controls	Location	Requirement
<b>Setbacks</b>		
<b>Basement:</b>	All boundaries:	Nil permitted
<b>Ground Floor – podium*:</b> (measured from lot boundary)	All roads	3.0m average/no maximum
<b>Above podium:</b> (measured from building edge)	All roads:	3.0m minimum/no maximum
<b>Top two storeys:</b> (for buildings in excess of 8 storeys – measured from building edge)	All roads:	2.0m minimum/no maximum
<b>Building Break</b>	The building design shall include a minimum of one physical break to the podium facade at boundary indicated.	
<b>Noise Attenuation</b>	Lots adjacent Beeliar Drive may be affected by noise. Development applications must be accompanied by an acoustic report addressing all relevant requirements.	

\* Refer to performance based bonus criteria outlined at section 6.3.

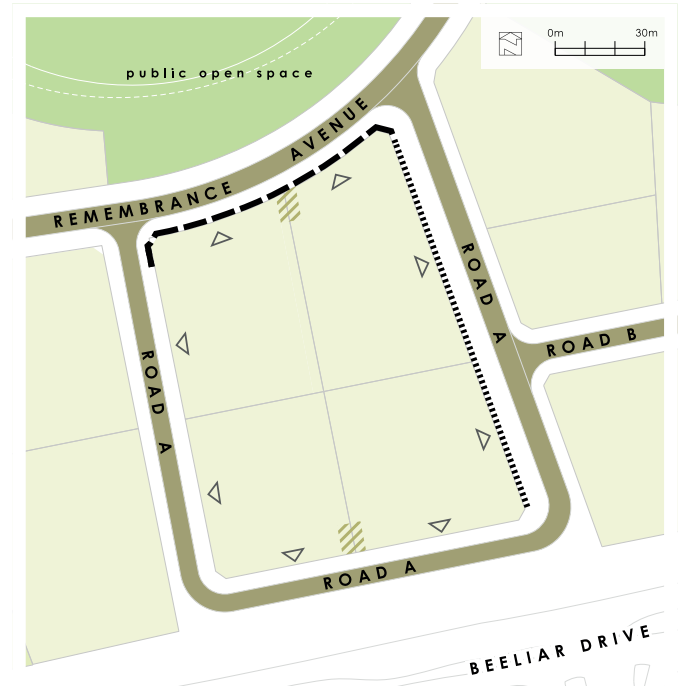

Site Diagram

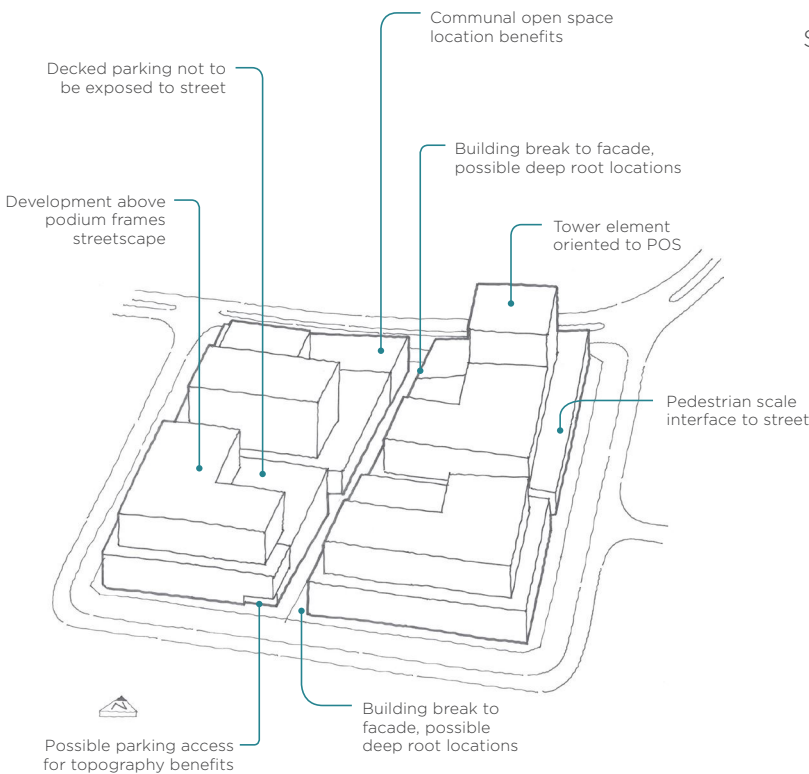

Indicative Principles Diagram

### LEGEND

#### Building Zones

- Public Open Space Interface Treatment Requirements (refer sections 6.5, 7.2, 7.3, 7.7 & 7.9)
- 4st Minimum 4 storeys (no max)
- ★ Landmark Building (specific corner design requirements, refer 6.5)
- ▽ Priority Facade - Building Orientation
- Communal Private Open Space Priority Zone (located on podium)
- Preferred (Priority) location for building height over 5 storeys
- View corridor/building break requirement at ground level
- Construction Zone
- Public Utility Buffer -15m (ATCO Gas)
- Service Infrastructure (approx. alignment)

#### Landuse

- Mandatory Non-Residential Landuse - Ground Floor
- Non-Residential Landuses Encouraged - Ground Floor

#### Movement

- No Vehicle Access Permitted
- Vehicle Access Permitted where the access point is not dominant within the building facade

Site Diagram Legend



# 10. SITE SPECIFIC BUILDING REQUIREMENTS

\* to be read in conjunction with relevant General Provisions.

## SITE 11

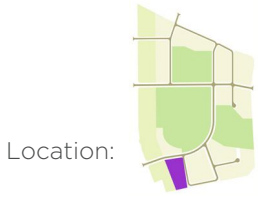

Key Controls	Location	Requirement
<b>Setbacks</b>		
<b>Basement:</b>	All boundaries:	Nil permitted
<b>Ground Floor – podium*:</b> (measured from lot boundary)	All roads	3.0m average/no maximum
	Public Utility Reserve:	Nil permitted/no maximum <sup>1</sup>
<b>Above podium:</b> (measured from building edge)	All roads:	3.0m minimum/no maximum
	Public Utility Reserve:	Nil permitted/no maximum <sup>1</sup>
<b>Top two storeys:</b> (for buildings in excess of 8 storeys – measured from building edge)	All roads:	2.0m minimum/no maximum
	Public Utility Reserve:	Nil permitted/no maximum <sup>1</sup>
<b>Service Infrastructure</b>	<sup>1</sup> Development setback subject to infrastructure specific requirements. Developers should satisfy themselves of detailed requirements.	
<b>Noise Attenuation</b>	Lots adjacent Beelias Drive may be affected by noise. Development applications must be accompanied by an acoustic report addressing all relevant requirements.	

\* Refer to performance based bonus criteria outlined at section 6.3.

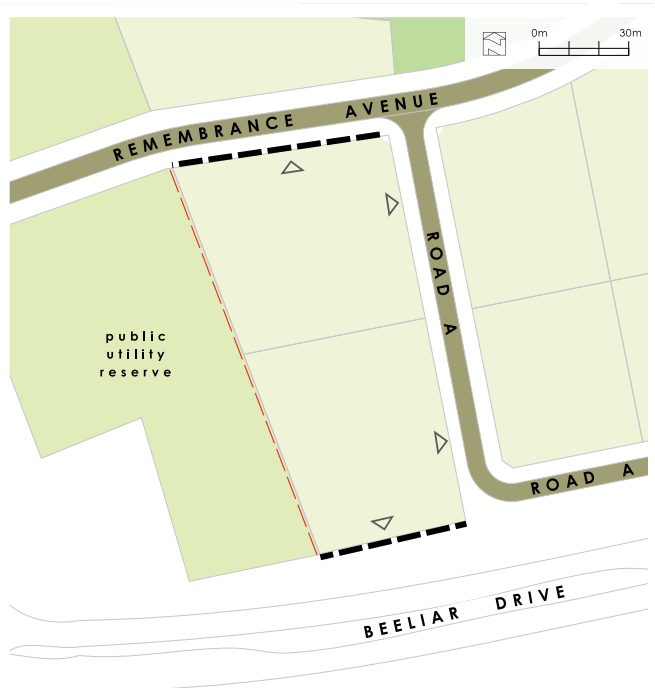

Site Diagram

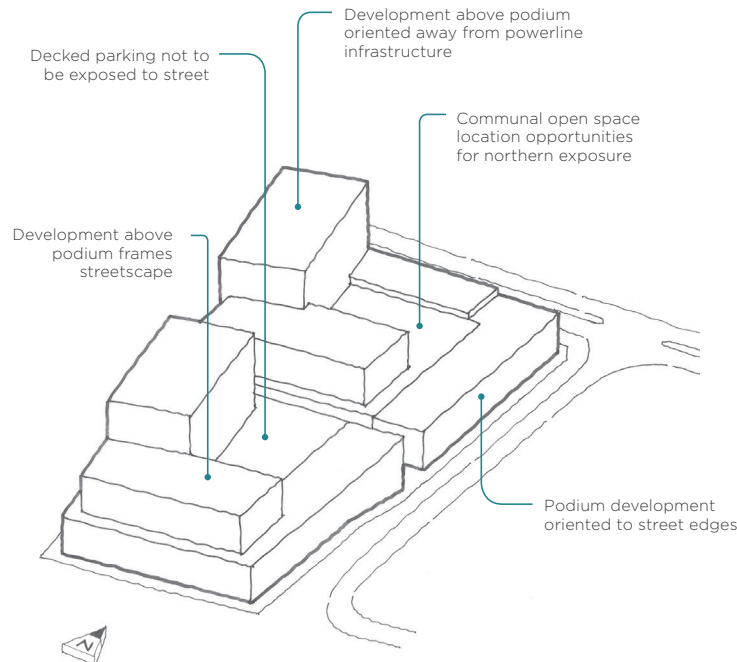

Indicative Principles Diagram

**LEGEND**

**Building Zones**

- Public Open Space Interface Treatment Requirements (refer sections 6.5, 7.2, 7.3, 7.7 & 7.9)
- 4st Minimum 4 storeys (no max)
- ✳️ Landmark Building (specific corner design requirements, refer 6.5)
- ▽ Priority Facade - Building Orientation
- ▨ Communal Private Open Space Priority Zone (located on podium)
- ▭ Preferred (Priority) location for building height over 5 storeys
- ▨ View corridor/building break requirement at ground level
- ▭ Construction Zone
- ▨ Public Utility Buffer -15m (ATCO Gas)
- ← Service Infrastructure (approx. alignment)

**Landuse**

- ▭ Mandatory Non-Residential Landuse - Ground Floor
- ▭ Non-Residential Landuses Encouraged - Ground Floor

**Movement**

- No Vehicle Access Permitted
- ⋯ Vehicle Access Permitted where the access point is not dominant within the building facade

Site Diagram Legend

# 10. SITE SPECIFIC BUILDING REQUIREMENTS

\* to be read in conjunction with relevant General Provisions.

## SITE 12

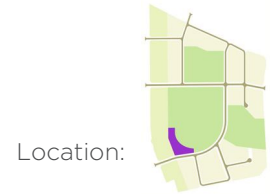

Key Controls	Location	Requirement
<b>Setbacks</b>		
<b>Basement:</b>	All boundaries:	Nil permitted
<b>Ground Floor – podium*:</b> (measured from lot boundary)	All roads	3.0m average/no maximum
	Public Utility Reserve:	Nil permitted/no maximum
<b>Above podium:</b> (measured from building edge)	Public Open Space frontage:	3.0m minimum/no maximum
	All roads:	3.0m minimum/no maximum
<b>Top two storeys:</b> (for buildings in excess of 8 storeys – measured from building edge)	Public Utility Reserve:	Nil permitted/no maximum
	Public Open Space frontage:	3.0m minimum/no maximum
<b>Service Infrastructure</b>	All roads:	2.0m minimum/no maximum
	Public Utility Reserve:	Nil permitted/no maximum
	Public Open Space frontage:	2.0m minimum/no maximum
<b>Building Height</b>	Development setback subject to infrastructure specific requirements. Developers should satisfy themselves of detailed requirements.	Building tower element restrictions apply – refer general provisions

\* Refer to performance based bonus criteria outlined at section 6.3.

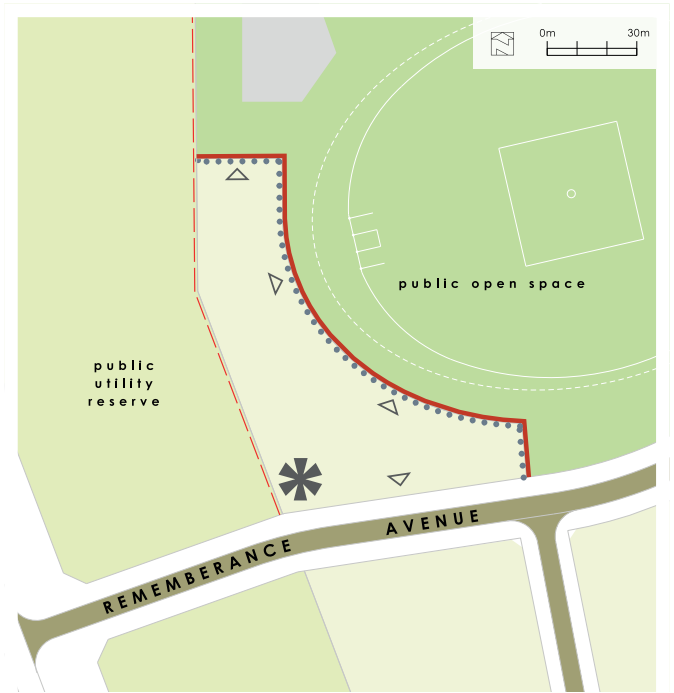

Site Diagram

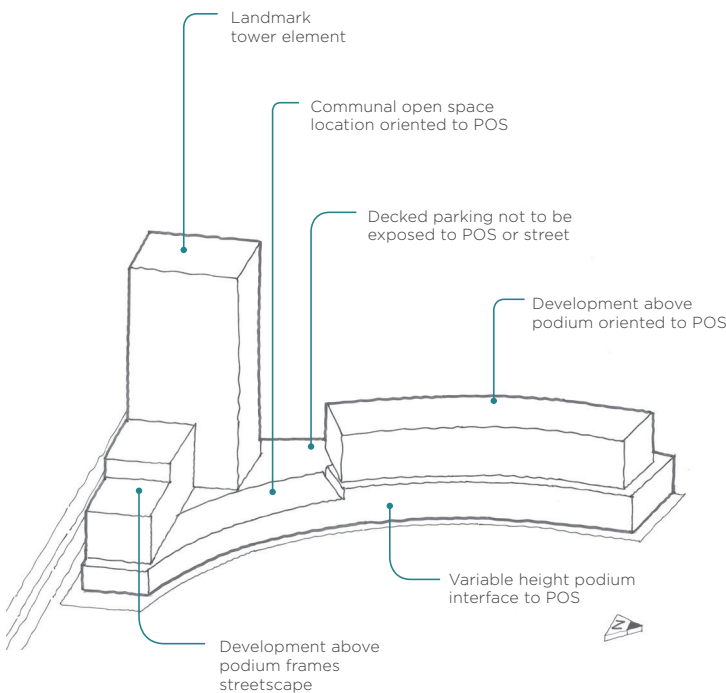

Indicative Principles Diagram

### LEGEND

#### Building Zones

- Public Open Space Interface Treatment Requirements (refer sections 6.5, 7.2, 7.3, 7.7 & 7.9)
- 4st Minimum 4 storeys (no max)
- ★ Landmark Building (specific corner design requirements, refer 6.5)
- ▽ Priority Facade - Building Orientation
- Communal Private Open Space Priority Zone (located on podium)
- Preferred (Priority) location for building height over 5 storeys
- View corridor/building break requirement at ground level
- Construction Zone
- Public Utility Buffer -15m (ATCO Gas)
- Service Infrastructure (approx. alignment)

#### Landuse

- Mandatory Non-Residential Landuse - Ground Floor
- Non-Residential Landuses Encouraged - Ground Floor

#### Movement

- No Vehicle Access Permitted
- Vehicle Access Permitted where the access point is not dominant within the building facade

Site Diagram Legend

**APPLICATION FORM 1**

**DESIGN ENDORSEMENT**

**SITE AND OWNERS DETAILS**

Lot Number:	
Street Name:	
Owners Name/s:	
Contact Address	
Owners Phone:	
Owners Email:	

**APPLICANTS DETAILS (if not owner)**

Business Name:	
Applicant's Name:	
Applicant's Address:	
Applicant's Phone	
Applicant's Email	

**SUBMISSION REQUIREMENTS (please tick)**

1. Two sets of drawings.	<input type="checkbox"/>
2. A completed Development Controls checklist is attached.	<input type="checkbox"/>

**SUBMITTED DRAWINGS (please tick)**

Site Plan	<input type="checkbox"/>
Floor Plan of each level	<input type="checkbox"/>
Roof Plan	<input type="checkbox"/>
Coloured Elevations	<input type="checkbox"/>
Building sections	<input type="checkbox"/>
Solar Access Diagrams	<input type="checkbox"/>
Colour scheme and material selection	<input type="checkbox"/>
Landscape Plan	<input type="checkbox"/>
Others: (specify)	<input type="checkbox"/>
Development Application Report Outline	<input type="checkbox"/>

Note: Drawings to be numbered and dated.

**DESIGN REVIEW PANEL STAMP**

**CERTIFIER'S AUTHORISATION**

We declare that this proposal, as outlined on the documentation listed above, satisfactory complies with Cockburn Central West Design Guidelines.

Signature of assessor:	
Name of assessor:	
Date of assessment:	

## APPENDIX A

### DEVELOPMENT CONTROLS CHECKLIST

MARK Y (YES) N (NO) OR N/A (NOT APPLICABLE) IN THE DTC (DEEMED TO COMPLY) COLUMN ACCORDING TO WHETHER YOUR PROPOSAL COMPLIES WITH THE ASSOCIATED CHECKLIST ITEMS. IF PROPONENT BELIEVES THE RELEVANT DEVELOPMENT CONTROLS CAN BE MET IN AN ALTERNATIVE WAY, MARK THE P (PERFORMANCE) COLUMN AND ATTACH RELEVANT JUSTIFICATION WHEN A PERFORMANCE SOLUTION IS SOUGHT.

		DTC	P
<b>6.0</b>	<b>URBAN DESIGN</b>		
<b>6.3</b>	<b>Diversity &amp; Ground Floor Adaptability</b>		
a	Adaptable buildings shall have a minimum ground floor to first floor ceiling height of 4.1m in their residential form. This is intended to achieve a 3.5m clearance height when converted to non-residential uses.		
b	For adaptable buildings, floating floors may be included for interim residential use where ground level separation is desirable to the public realm. This can be removed when floor space is adapted to non-residential tenancies.		
c	To achieve diversity in unit size and affordability, residential development shall provide a minimum of 20% one bedroom dwellings and 40% two bedroom dwellings in any one development. A balance of three bedroom units is also strongly encouraged to ensure a diverse range of apartment sizes across the Activity Centre Core Area. Development applications shall be supported with a short written statement advising how the proposed development is contributing to the objective of diverse dwelling sizes. Information regarding current dwelling yields, including mix within the Activity Centre Core Area is available from the City upon request.		
d	Non-residential ground floor development shall be provided where mandated on the Site Specific Building Requirements (section 10).		
e	Residential ground floor dwellings shall be adaptable to commercial/retail where nominated as 'non-residential land use encouraged' within the Site Specific Building Requirements (section 10).		
f	Where residential use is to occur at the ground floor in areas nominated as 'non-residential land use encouraged', street elevations shall be designed in the first place as commercial/retail type frontages rather than domestic in scale and design aesthetic.		
<b>6.4</b>	<b>Place Legibility</b>		
a	Development shall respond to key vistas and public open space through the positioning, orientation and massing of buildings, landmark and landscape elements.		
b	New developments shall integrate with existing Cockburn Central Town Centre development linkages and viewlines.		
c	Buildings on corners must address both frontages to the street and/or public space and include strong architectural expression.		
d	For Landmark Building locations, design excellence is required in the form of articulation of the building design, proportion, quality, scale, massing and detailing.		
<b>6.5</b>	<b>Public Domain Interface</b>		
a	Pedestrian access to public open space from adjacent lots shall be provided and integrated into site planning (excluding lots 118, 119 and 120 adjacent to playing fields).		
b	Developments on corner lots shall address both the primary and secondary streets and/or public realm and include strong architectural expression.		
c	Where Pedestrian Access Ways are located, buildings shall achieve appropriate surveillance of these spaces.		
d	Blank walls, vehicle access and building services (e.g. bin store, booster hydrant) shall not exceed 20% of the total lot frontage to the public realm, except for developments on corners where no blank walls will be permitted.		



		DTC	P
e	Ensure a fine grain design for the ground plane to promote a sense of layering, texture and visual interest to enhance depth and character of building facades.		
<b>6.6</b>	<b>Development Context</b>		
a	Design of individual sites must be responsive to neighbouring sites, the existing context and the public realm and provide a positive contribution to the project area as a whole.		
<b>6.7</b>	<b>Public Art</b>		
a	Public art elements shall involve a professional artist and shall be submitted for the approval of the DRP with application for Design Guideline endorsement.		
b	All development proposals shall accord with City of Cockburn Local Planning Policy APD80 requirements and eligibility details.		
<b>6.8</b>	<b>Safety and Surveillance</b>		
a	The size and position of windows from habitable rooms, balcony openings, hospitality and commercial areas shall be designed to promote natural surveillance of the public realm.		
b	Developments are to incorporate design principles of Crime Prevention Through Environmental Design (CPTED).		
c	Developments should be designed to engage with and activate the public realm, particularly at ground level.		
d	Proposed pedestrian access ways shall provide adequate lighting and natural surveillance to meet the CPTED guidelines for safety.		
e	Proposed pedestrian access ways shall provide adequate lighting and natural surveillance to meet the CPTED guidelines for safety.		
<b>6.9</b>	<b>Access and Parking</b>		
<b>6.9.1</b>	<b>Access</b>		
a	Crossovers shall not interfere with existing or proposed street trees, or the levels of pavement.		
b	Crossovers should be constructed from a material consistent with the design treatment of the streetscapes and generally respond to the materiality of the verge hard-scaping, either as constructed or proposed. Asphalt crossovers are not permitted.		
c	Paving to vehicle access ways shall be of an equivalent quality to paving used within public realm, while meeting the requirements of heavy vehicles.		
d	Footpaths shall be maintained as the priority movement, with crossovers and car park entries terminating at the footpath. Where vehicle crossovers are agreed with the DRP and cross a key pedestrian route, appropriate measures to promote pedestrian safety shall be included to minimise conflict between pedestrians and vehicle traffic.		
e	Car park entries shall be positioned to minimise visual impact from the public realm and located away from main pedestrian entries. Vehicular access is preferable from a laneway, where possible. Refer Site Specific Building Requirements (section 10).		
f	Car park entries and crossovers shall comply with the Australian Standards.		
g	Car park entries, service areas and bin refuse collection points shall be integrated into the development of each lot and screened from view.		
h	For all proposed commercial or retail tenancies, a Servicing Management Strategy is to be prepared in conjunction with City of Cockburn.		
<b>6.9.2</b>	<b>Vehicle Parking</b>		
a	Any above grade parking adjacent priority streets and public realm areas shall be sleeved with habitable/active uses (residential, retail or commercial).		
b	Basement or concealed decked parking shall not be visible from the street or public realm and shall be screened by innovative wall detailing, patterning and vegetation to diversify the building design.		
c	Basement level parking development is limited to a maximum height of 1.2m above ground level where the property interfaces with the public realm.		

		DTC	P
d	Parking bay(s) shall comply with the Australian Standards.		
e	The maximum width of car parking and basement access shall be 6.5m and shall not be co-located.		
f	Ground floor parking shall not be proposed within the front setback area.		
g	Lighting design for parking outcomes shall consider light spill and amenity for apartments (on-site and adjacent developments).		
h	Any open air parking outcomes shall minimise adverse visual impacts for overlooking residents, which should include screening such as shade structures.		
<b>6.10</b>	<b>Signage (Commercial Development Only)</b>		
a	Signage shall be located on a maximum of one wall for each commercial tenancy within a building, except where a tenancy or building has more than one street frontage.		
b	Pole or pylon signs and illuminated roof signs are prohibited.		
c	All signage must meet criteria noted in current Local Planning Scheme and relevant local planning policy by laws (including the City of Cockburn's Signage Local Planning Policy) and have an approved signage design as part of the Development Application prior to placement of any signage or advertising on commercial development.		
<b>7.0</b>	<b>BUILT FORM DESIGN</b>		
<b>7.2</b>	<b>Primary Building Controls</b>		
<b>7.2.1</b>	<b>Site Planning, Orientation and Setbacks</b>		
a	All street setbacks where not specified in the site specific building requirements shall meet an average of 3m, with a minimum setback of 1.5m, measured from the lot boundary.		
b	Development above podium height (3-5 storeys) shall set back a minimum of 3 metres from the street building edge, except locations where an alternative setback is set in the Site Specific Building Requirements (section 10).		
c	A minimum open space of 20% of the lot shall be required (excluding balconies and driveways).		
d	Development shall comply with Figure 7.2.1 for street, laneway, rear and public open space setbacks.		
e	Minimum side and rear setback distances for podium elements of the buildings shall be:		
f	- 6m between walls with major openings/balconies		
g	- 4.5m between walls with major openings/balconies and walls with no major openings		
h	- 3m between walls with no major openings		
i	- 0m for party walls, parking structures or walls with no openings		
j	Balconies shall be located entirely within the lot boundary.		
<b>7.2.1.1</b>	<b>Tower Setbacks</b>		
a	Minimum side and rear boundary setback distances for buildings above the podium shall be determined by conditions detailed at Figure 7.2.1.1.		
<b>7.2.2</b>	<b>Building Separation</b>		
a	Minimum separation distances between podium elements of the buildings shall be:		
	- 12m between walls with major openings/balconies		
	- 9m between walls with major openings/balconies and walls with no major openings		
	- 6m between walls with no major openings		
b	Minimum tower separation distances are detailed at Figure 7.2.2 and are to be set back from each other as though there were a boundary between them.		
c	Facade building breaks are required in key locations as noted on the Site Specific Building Requirements (section 10).		

		DTC	P
d	Building separation is measured from the outer face of building envelopes (including balconies).		
<b>7.2.2.1</b>	<b>Tower Building Envelopes</b>		
a	Tower building envelopes are determined by applicable setbacks to site boundary and/or podium building edge (refer 7.2.1).		
b	For developments of 8 storeys or below, there is the flexibility to incorporate more than one tower. The maximum combined tower floorplate is equivalent to 60% of the tower envelope.		
c	For all building heights of 9 storeys and above: development sites shall be restricted to 1 tower element only per 2500m <sup>2</sup> of lot site area. E.g.: If 3 lots were amalgamated by landowners, and the total land area was less than 1.0ha, then there is the potential that 3 towers may be achievable.		
d	For developments of 9 storeys and above, the tower element is restricted to the maximum dimensions of 900m <sup>2</sup> maximum (approximately 45m x 20m). For developments that abut the northern boundary of POS, the shorter side of the tower dimension shall orient to the POS.		
<b>7.2.3</b>	<b>Height</b>		
a	All development shall be a minimum of three storeys along street frontages except where noted on Site Specific Building Requirements.		
b	Building Height may be reduced to two storeys to allow for attached grouped dwellings, providing the extent of grouped dwellings does not exceed 30% of the developable land area within any parcel of land.		
c	All multiple dwelling development shall include a podium with a height minimum of 3 storeys and a maximum of 5 storeys.		
d	Maximum building height will be guided by limitations imposed by the Jandakot Airport flight path contours and where noted on Site Specific Building Requirements (section 10).		
e	Refer to the below website for additional information:		
f	<a href="http://www.jandakotairport.com.au/images/files/ControlledActivity/Jandakot-OLS.pdf">www.jandakotairport.com.au/images/files/ControlledActivity/Jandakot-OLS.pdf</a>		
<b>7.2.4</b>	<b>Floor Levels</b>		
a	Floor to floor heights on the ground floor retail and commercial tenancies shall be a minimum of 3.5m, except for food and beverage tenancies which shall be minimum of 4.0m. This may only be varied to meet site specific level constraints at discretion of DRP.		
b	For commercial tenancies, changes in internal floor levels shall be a maximum of 1.2m (parallel with the street). Where larger internal level changes are needed, they shall occur at least 5m back from the building edge.		
c	To provide direct access to ground floor active use premises (at point of access), finished floor levels are to correspond to the adjacent footpath for universal access.		
d	Residential developments shall have minimum floor to ceiling height of 2.7m to habitable rooms.		
e	Residential ground floors shall not be more than 0.9m above natural ground level at any point.		
<b>7.3</b>	<b>Architectural Character</b>		
a	Long street facades shall contain building breaks at a maximum of every 40m.		
b	Continuous horizontal and vertical elements shall be broken into smaller components through architectural features, materials, textures and building breaks.		
c	Street level awnings with a minimum width of 2.0m must be provided to ground floor commercial/retail developments.		
d	Street level awning structures shall be a minimum 2.7m and maximum 3.5m above the footpath.		

		DTC	P
<b>7.3.1</b>	<b>Facades</b>		
a	The character and composition of the building elevations shall respond to the specified edge conditions within the precinct (Figure 7.3.1).		
b	Four distinct elevation types shall be reflected as indicated in Figure 7.3.2.		
c	The appropriate facade treatments shall: <ul style="list-style-type: none"> <li>- Achieve enclosure and privacy from westerly sun, powerlines, and road noise and create a formal urban edge.</li> <li>- Achieve a sense of privacy and protection from road noise without dominating the adjacent public realm and development.</li> <li>- Take advantage of the internal views of the open space, create a sense of ownership and achieve surveillance.</li> <li>- Additional screening may be required for protection from westerly sun and wind patterns. Facades should maintain their internal views of the open space to create a sense of ownership and achieve surveillance.</li> </ul>		
<b>7.4</b>	<b>Materials and Colours</b>		
a	Developments shall incorporate a variety of materials such as rendered masonry, face brick, stone, steel, glazing and cladding materials, to achieve a contemporary urban aesthetic.		
b	Consideration of thermal and general environmental performance shall be demonstrated in the selection of materials and colours.		
c	Each application for planning approval is to be accompanied with details on proposed materials and colours, together with sample swatches.		
<b>7.5</b>	<b>Building Entrances</b>		
a	Pedestrian entrances shall be clearly defined and separate from vehicle access.		
b	Commercial and residential entries shall be separate and well defined.		
c	Entries for the ground floor level and upper level areas shall be designed separate.		
d	Building entrances shall be designed and located to be highly visible, sheltered, well lit spaces that optimise the safety and convenience of residents and visitors.		
e	Building entrances shall be designed to assist with interest and fine grain at the ground level.		
f	Where long ramps are required to any public street frontage, they should be provided wholly or partially within the building rather than externally to reduce their visual impact and assist in achieving a strong built edge to the street boundary.		
<b>7.6</b>	<b>Roof Forms</b>		
a	Design consideration shall be given to the view of the roof, roof plant equipment and cantilevered elements (e.g. awnings) from adjacent streets, taller buildings and the greater public realm (including ovals and parklands).		
b	Illuminated signage is not permitted as part of the roof design.		
c	Details of air conditioning and roof plant equipment to be discussed at design review stage.		
<b>7.7</b>	<b>Outdoor Space</b>		
<b>7.7.1</b>	<b>Communal Outdoor Areas</b>		
a	Passive solar access to usable outdoor areas shall be optimised.		
b	Where lots directly abut public open space, communal open space location shall be prioritised to be accessible from, or provide a direct visual connection to these areas.		
c	A minimum open space of 20% of the lot area shall be required (excluding balconies and driveways).		
d	Where communal open space cannot be provided on the ground level, it should be provided on a podium or roof.		



		DTC	P
<b>7.7.2</b>	<b>Private Outdoor Living Areas</b>		
a	All apartments shall be provided with at least one balcony or equivalent accessed directly from a habitable room with a minimum area of 10m <sup>2</sup> and a minimum dimension of 2.5m. Studio apartments 40m <sup>2</sup> and smaller may have a Juliette balcony (full height opening windows with a balustrade).		
b	Balconies, terraces, or courtyards are to be provided for all dwellings fronting the public realm.		
c	Balcony balustrades shall be visually permeable to 50% of the area.		
d	All ground level dwellings shall have an outdoor living area relative to the size of dwelling, directly accessible from an internal living space:		
	- <80sqm dwelling = 12sqm min. outdoor space		
	- 80-120sqm dwelling = 16sqm min. outdoor space		
	- >120sqm dwelling = 20sqm min. outdoor space		
e	Overlooking between balconies and adjoining residences shall be carefully considered and privacy screening provided where necessary.		
f	A balcony that is fully enclosed by operable louvers, sliding panels or bi-fold doors and has a hard floor surface continuous with the internal area can be included as private open space.		
<b>7.8</b>	<b>Building Services</b>		
<b>7.8.1</b>	<b>Waste Management</b>		
a	An integrated Waste Management Strategy shall be prepared in consultation with City of Cockburn.		
b	Waste storage facilities shall be designed to allow collection of waste from within the site or a strategy for transfer of waste developed within the waste management strategy.		
c	Waste collection areas shall be located and designed so they are not visible from the public realm and screened from view.		
d	Waste collection areas shall be located behind the primary building line, incorporated into the building with a quality material, compatible with the building design.		
e	Bin storage areas shall be located to minimise the impact on adjoining residences and screened from public view.		
<b>7.8.2</b>	<b>Drying Areas</b>		
a	A naturally ventilated drying cupboard/area shall be provided to each dwelling. This may be within a secondary balcony if provided.		
b	Any drying area shall be screened from view but well ventilated.		
<b>7.8.3</b>	<b>Storage</b>		
a	Adequate storage for non-residential functions shall be incorporated into the building design.		
b	Storage not located in apartments shall be conveniently located, accessible and nominated for individual apartments.		
c	Storage areas shall be a minimum of 4m <sup>2</sup> per dwelling.		
d	A minimum of 50% of the required storage shall be located within the apartment.		
e	Storage areas at the rear of parking bays must not impede parking access and should contain a roller or sliding door.		
<b>7.8.4</b>	<b>Mechanical Services</b>		
a	Piped and wired services including conduit shall be concealed from view or integrated into the building design.		
b	Building services, including air conditioning units, satellite dishes and other plant equipment shall be screened from view or not be visible from the public realm and minimise acoustic or other impacts.		

		DTC	P
c	Building services, including air conditioning units and condensers, shall not be located on balconies or viewed from the public or private realm, unless screened from view in such a way as to be integrated into the building form.		
d	Meter boxes and letter boxes shall be contained within development lots, screened and integrated into the overall development.		
e	Car park venting/service lids and other utility infrastructure or equipments shall not be visible from the adjacent public or private realm and shall be appropriately screened to ensure they do not detract from the visual quality of the development.		
f	Plant, service equipment and lift overruns shall not be visible from the public realm and must not be visible above the roof line of building with street facing elevations.		
<b>7.8.5</b>	<b>End of Trip Facilities</b>		
a	For commercial and retail development with floorspace greater than 500m <sup>2</sup> NLA but less than 2000m <sup>2</sup> NLA, there shall be an allocation of one unisex shower or 1 male/1 female shower.		
b	For commercial and retail development with NLA floorspace greater than 2000m <sup>2</sup> NLA, there shall be an additional allocation of one unisex shower or 1 male/1 female shower per 2000m <sup>2</sup> thereafter.		
c	For all commercial and retail development, there shall be an allocation of one locker per bicycle storage space.		
d	All end of trip facilities shall be designed with convenience and safety in mind.		
<b>7.9</b>	<b>Fencing and Balustrades</b>		
a	Front fences, balustrades and gates addressing streets shall be at least 60% visually permeable by area, no more than 1.2 m high and uniform in design.		
b	All fencing, balustrades and gates addressing POS shall be at least 60% visually permeable by area and no more than 1.5 m high.		
c	Front fencing and balustrades shall be designed to complement the built form design.		
d	Colorbond and super six style fencing is not permitted.		
e	Closable louvre-style fins are not permitted for fencing abutting the street or public realm at ground level.		
<b>8.0</b>	<b>ENVIRONMENTALLY SUSTAINABLE DEVELOPMENT</b>		
<b>8.1</b>	<b>Climate Responsive Design</b>		
<b>8.1.1</b>	<b>Solar Design</b>		
a	Minimum 70% of all residential apartments shall receive 2 hours direct sunlight to major living areas between 9am and 3pm mid-winter.		
b	Shadow studies are required on buildings over 10m in height.		
c	It is desirable for at least 70% of dwellings in multi-residential developments to have outdoor areas that benefit from a northerly aspect.		
d	A Site Plan shall be prepared to demonstrate solar design outcome for the DRP assessment.		
<b>8.1.2</b>	<b>Shading</b>		
a	Openings not shaded by appropriate eave overhangs shall be shaded with an appropriate shading device e.g. awning, louvre that enable winter sun penetration while keeping out summer sun.		
b	Glazing to habitable rooms facing east and west shall have vertical protection, such as louvered solar-shutters, blinds or screening devices.		
c	West-facing outdoor living areas shall be provided with shading devices to provide sun control.		

		DTC	P
<b>8.1.3</b>	<b>Ventilation</b>		
a	Maximise natural ventilation potential by orienting buildings and their openings to maximise air intake from the “windward” side of the building and by providing air outlets on the “leeward” side of the building.		
b	Use a range of appropriate apartment depths to ensure natural ventilation.		
c	Residential dwellings shall be designed to maximise cross ventilation by providing direct breeze paths for cooling and air circulation.		
d	A minimum of 60% of apartments shall be naturally cross ventilated. Some discretion may be permitted to apartments where a carpark is required to be sleeved by the building adjacent public realm.		
e	Glazing systems shall be installed with draught seals/weather stripping.		
<b>8.2</b>	<b>Energy Efficiency</b>		
	(Required at Building Permit stage)		
a	The overall building shall achieve at least an average 5 Star NatHERS rating.		
b	Air-conditioning systems and other energy efficient appliances shall be minimum 5 star energy rating and sized appropriately for the space.		
c	A demonstrated highly energy efficient hot water system shall be installed (e.g. gas or solar boosted gas - centralised or local).		
<b>8.3</b>	<b>Water Efficiency</b>		
<b>8.3.1</b>	<b>Plumbing Fixtures</b>		
a	Tapware and showers should exceed National Construction Code requirements for WELS star ratings by one star per fixture.		
<b>8.3.2</b>	<b>Stormwater Management</b>		
a	All 1:100 year stormwater volumes shall be contained within the development site for multiple residential and mixed use developments.		
b	In accordance with AS/NZS 3500.3.		
<b>8.4</b>	<b>Lighting</b>		
a	Lighting shall be provided under awnings to illuminate the footpath below.		
b	All outdoor lighting shall be directed downwards with no light spill above the horizontal plane.		
c	Front outdoor/security lights shall be operated via a timed motion sensor with manual over-ride.		
d	Rear outdoor areas adjacent to laneways shall be well lit and incorporate motion activated light fittings.		
<b>8.5</b>	<b>Acoustics</b>		
<b>8.5.1</b>	<b>Landuse Generated Noise</b>		
a	Prior to submission of a Development Application an acoustic assessment shall be prepared in accordance with City of Cockburn Noise Attenuation Local Planning Policy requirements for all development proposals within Cockburn Central West.		
<b>8.5.2</b>	<b>Road Noise</b>		
a	Prior to submission of a Development Application an acoustic assessment shall be prepared in accordance with City of Cockburn Local Planning Policy APD83 requirements for buildings on lots affected by noise from Beeliar Drive, Midgegooroo Avenue and North Lake Road as identified in Herring Storer’s Acoustic Assessment (November 2014).		

		DTC	P
<b>9.0</b>	<b>LANDSCAPE DESIGN</b>		
<b>9.1</b>	<b>Deep Root Zones</b>		
a	For development incorporating residential landuse at the ground floor, a minimum 25% of the sites open space requirement shall be provided as deep root zone.		
b	A deep root zone shall not be covered by buildings or structures within a development. They can be co-located with communal open space but exclude all impervious surfaces.		
c	Deep root zones shall be located to allow for the mature development of trees with large canopies.		
d	Weed potential plants shall be avoided.		
e	The use of tree species which encourage foraging and roosting by birds is encouraged.		
f	Where the deep root zone controls are not achievable on a site due to the location or building typology, acceptable stormwater management shall be achieved and alternate forms of planting provided such as on structure.		
g	Species selection to be of an appropriate scale to the building.		
<b>9.2</b>	<b>Hardscaping</b>		
a	Hard stand areas shall be designed so that heat retention and re-radiation is minimised so the increase in ambient air temperature around buildings is contained.		
b	Minimise the extent of paving, or use permeable paving, to increase stormwater permeability.		
c	Vehicular surfaces, pedestrian entries, external foyer spaces and ground floor setback areas which are accessible to the public shall be treated with materials and colours sympathetic to those used in the adjacent public realm. This may include, but not limited to, paving, edging, walling, balustrades, handrails, steps, fencing, plant species, furniture, lighting and signage.		
d	Publicly-accessible areas shall be designed to suit individuals requiring universal access (IRUA).		
e	Damage to public realm works shall be rectified by the developer at the developer's expense to match pre-existing works.		
<b>9.3</b>	<b>Softscaping</b>		
a	A landscape concept design is required at design review meeting with the DRP.		
b	A landscaping plan shall be submitted detailing plant types, number, irrigation and mulch type for Building Permit.		
c	Landscaping will be designed with a view to CPTED principles and allow development to take advantage of views over open space while assisting with creation of an attractive urban edge with landscaping on verge and near-verge areas to soften the appearance of buildings and provide shading.		
d	At least 50% of the proposed plants shall be Western Australian native species.		
e	Use of predominantly low understorey shrub and groundcover species of less than 1 metre mature height.		
f	Use of single-trunk tree species with a mature canopy starting point higher than 2.5 metres where pedestrian access and uninterrupted sightlines are required.		
g	Planting areas should be designed for full coverage.		
h	Species selection and planting themes shall respond to local conditions and relate to the character, scale and proportions of the streetscape and built form.		
i	Avoid the use of continuous lengths of blank walls on sites where outdoor space (private or communal) is raised over 0.5m above street level (or open space) by placing planting to soften the edges and reduce their apparent scale.		
<b>9.4</b>	<b>Water Efficiency and Maintenance</b>		
a	An irrigation plan shall be included as part of the Landscape Plan for Building Approval.		
b	The use of water efficient irrigation shall be installed for all garden beds.		



		DTC	P
c	Private water bores are not permitted.		
d	Spray irrigation may be used on turf areas only.		
e	An automatic irrigation system including a rain sensor shall be installed that adheres to current Water Corporation water usage standards and restrictions.		
f	Developments shall allow water to permeate the ground surface by maximising permeable ground surface treatment such as gravel, crushed stone, permeable paving or pavers on a sand base.		
g	Maintain landscape areas to a high level of presentation consistent with the overall character of the streetscape and precinct.		
h	All vegetation shall be maintained so as not to obstruct pedestrian and vehicular access or sightlines.		
<b>9.5</b>	<b>Construction Zone</b>		
a	A 'construction zone' of 2.0m width has been allowed for in the design of the public open space areas. This zone is available for temporary use by the building developer to facilitate the building construction process. At the end of the construction process, the land owner will be responsible for landscape construction within the construction zone.		
b	Final landscaping of the construction zone shall be completed to the satisfaction of the City of Cockburn.		
c	Locations and extent of Construction Zone are detailed on the Site Specific Building Requirements (section 10).		

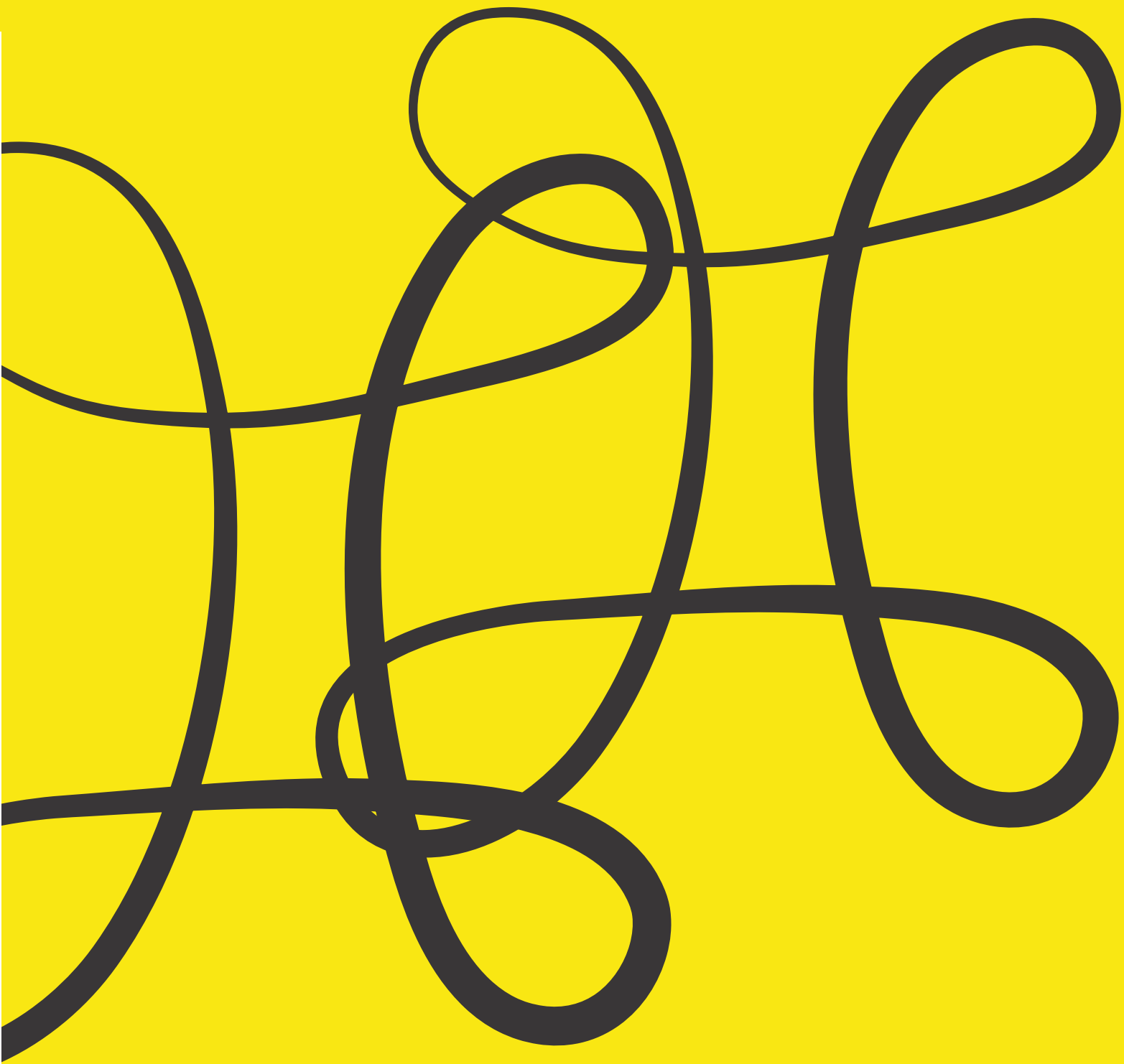

Disclaimer: The information contained in this document is in good faith; however neither LandCorp nor any of its directors, agents or employees give any warranty of accuracy nor accepts any liability as result of a reliance upon the information, advice, statement or opinion contained in this document. Artists impressions and landscape vision are correct at time of production and subject to change. This disclaimer is subject to any contrary legislative provisions. LandCorp 2016. LC 4118 02/2016